

Review

A Modern Approach to Dyslipidemia

Amanda J. Berberich^{1,2} and Robert A. Hegele^{1,2}

¹Department of Medicine; Schulich School of Medicine and Dentistry, Western University, London, ON, Canada, N6A 5C1; and ²Robarts Research Institute, Schulich School of Medicine and Dentistry, Western University, London, ON, Canada, N6A 5B7

ORCID numbers: 0000-0003-2861-5325 (R. A. Hegele).

Abbreviations: ACS, acute coronary syndrome; ANGPTL, angiotensin-like protein; apo, apolipoprotein; ASCVD, atherosclerotic cardiovascular disease; ASO, antisense oligonucleotide; BAS, bile acid sequestrant; C, cholesterol; CE, cholesterol ester; CETP, cholesterol ester transfer protein; CHL, combined hyperlipidemia; CK, creatine kinase; CM, chylomicron; FCS, familial chylomicronemia syndrome; FDA, US Food and Drug Administration; FH, familial hypercholesterolemia; GalNAc, triantennary N-acetylgalactosamine; HDL, high-density lipoprotein; HL, hepatic lipase; HMGCR, 3-hydroxy-3-methylglutaryl CoA reductase; HoFH, homozygous familial hypercholesterolemia; HTG, hypertriglyceridemia; IDL, intermediate-density lipoprotein; LCAT, lecithin:cholesterol acyltransferase; LDL, low-density lipoprotein; LDLR, low-density lipoprotein receptor; LDLRAP1, low-density lipoprotein receptor adaptor protein 1; Lp(a), lipoprotein(a); LPL, lipoprotein lipase; PCSK9, proprotein convertase subtilisin/kexin type 9; SAMS, statin-associated muscle symptom; sdLDL, small, dense low-density lipoprotein; siRNA, small interfering RNA; SNP, single nucleotide polymorphism; TC, total cholesterol; TG, triglyceride; ULN, upper limit of normal; VLDL, very low-density lipoprotein

Received: 8 August 2021; Editorial Decision: 11 October 2021; First Published Online: 22 October 2021; Corrected and Typeset: 29 November 2021.

Abstract

Lipid disorders involving derangements in serum cholesterol, triglycerides, or both are commonly encountered in clinical practice and often have implications for cardiovascular risk and overall health. Recent advances in knowledge, recommendations, and treatment options have necessitated an updated approach to these disorders. Older classification schemes have outlived their usefulness, yielding to an approach based on the primary lipid disturbance identified on a routine lipid panel as a practical starting point. Although monogenic dyslipidemias exist and are important to identify, most individuals with lipid disorders have polygenic predisposition, often in the context of secondary factors such as obesity and type 2 diabetes. With regard to cardiovascular disease, elevated low-density lipoprotein cholesterol is essentially causal, and clinical practice guidelines worldwide have recommended treatment thresholds and targets for this variable. Furthermore, recent studies have established elevated triglycerides as a cardiovascular risk factor, whereas depressed high-density lipoprotein cholesterol now appears less contributory than was previously believed. An updated approach to diagnosis and risk assessment may include measurement of secondary lipid variables such as apolipoprotein B and lipoprotein(a), together with selective use of genetic testing to diagnose rare monogenic dyslipidemias such as familial hypercholesterolemia or familial

ISSN Print: 0163-769X
ISSN Online: 1945-7189
Printed in USA

© The Author(s) 2021. Published by Oxford University Press on behalf of the Endocrine Society. This is an Open Access article distributed under the terms of the Creative Commons Attribution-NonCommercial-NoDerivs licence (<https://creativecommons.org/licenses/by-nc-nd/4.0/>), which permits non-commercial reproduction and distribution of the work, in any medium, provided the original work is not altered or transformed in any way, and that the work is properly cited. For commercial re-use, please contact journals.permissions@oup.com

chylomicronemia syndrome. The ongoing development of new agents—especially anti-sense RNA and monoclonal antibodies—targeting dyslipidemias will provide additional management options, which in turn motivates discussion on how best to incorporate them into current treatment algorithms.

Key Words: cholesterol, triglycerides, lipoprotein(a), dyslipidemia, combined hyperlipidemia, atherosclerosis

Graphical Abstract

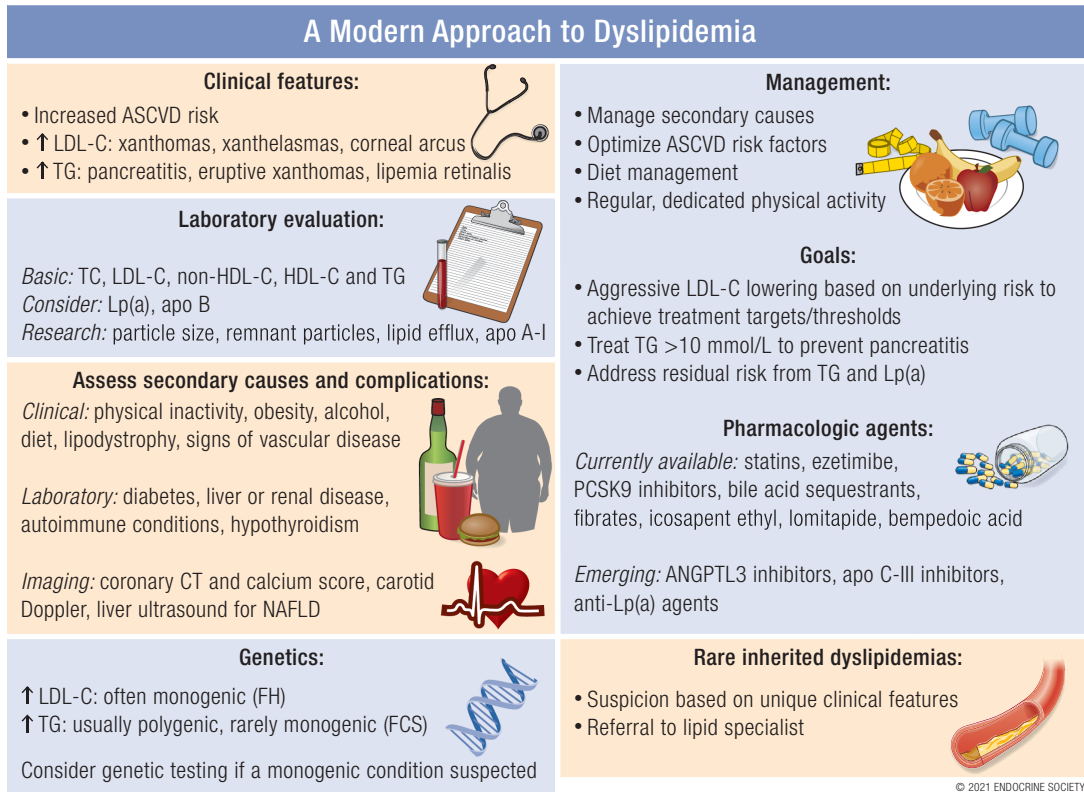

ESSENTIAL POINTS

- We suggest a simplified overall approach to classification and management of patients with dyslipidemias: hypercholesterolemia, hypertriglyceridemia, combined dyslipidemia or other.
- Additional tests such as apo B and Lp(a) can help precisely stratify vascular disease risk.
- Genetic testing may be helpful when monogenic dyslipidemias are strongly suspected.
- Hypercholesterolemia from elevated LDL-C is managed according to guidelines using statins, ezetimibe and anti-PCSK9 monoclonal antibodies; inclisiran, bempedoic acid and evinacumab are poised to fill unmet clinical needs.
- Intervention to prevent ASCVD in hypertriglyceridemia is currently limited to icosapent ethyl.
- Severely elevated TG levels can be reduced by fibrates to prevent pancreatitis; new agents targeting apo C-III mRNA will also be helpful for patients.
- Antisense agents and monoclonal antibodies targeting ANGPTL3 can correct several hyperlipidemias.
- Utility of antisense agents targeting Lp(a) will depend on cardiovascular outcome trials.
- Ruling out secondary factors, encouraging a prudent diet, exercise, and weight loss, along with global risk factor control remain the cornerstones of dyslipidemia management.

Dyslipidemias are collectively among the most commonly detected and treated chronic conditions. They are classically characterized by abnormal serum levels of cholesterol,

triglycerides, or both, involving abnormal levels of related lipoprotein species. The most commonly associated clinical consequence of dyslipidemia is increased

atherosclerotic cardiovascular disease (ASCVD) risk, which is associated with elevated total and low-density lipoprotein (LDL) cholesterol (C), triglycerides (TGs), and lipoprotein(a) (Lp(a)), as well as depressed high-density lipoprotein (HDL)-C. Secondary predisposing factors, in particular obesity and type 2 diabetes, are often present. Additional clinical consequences are also associated with rare dyslipidemias, including pancreatitis with severe elevations in TGs, as well as hepatosteatosis and fat-soluble vitamin deficiencies in individuals with genetically compromised production of apolipoprotein (apo) B-containing lipoproteins.

Dyslipidemias are an active and expanding area of research, with recent studies providing insight into their molecular basis and genetic origins, outlining their role in the development of atherosclerosis, and clarifying the ability of pharmacologic agents to ameliorate ASCVD risk in affected individuals. Management options for dyslipidemias are also expanding, including the well-established use of monoclonal antibodies targeting proprotein convertase subtilisin/kexin type 9 (PCSK9) for the management of hypercholesterolemia, the approval in Europe of volanesorsen, targeting apo C-III, for the management of familial chylomicronemia syndrome (FCS), as well as recent approvals in North America for bempedoic acid, evinacumab, and inclisiran for various indications related

to reduction of LDL-C. Several other agents are in late-stage clinical development, including those directed toward the novel targets of Lp(a) and angiotensin-like protein 3 (ANGPTL3).

It is therefore timely to consider an updated clinical approach to dyslipidemias. This review attempts to summarize previous knowledge and to highlight the implications of new developments, including a streamlined classification system for dyslipidemias, the potential value of measuring secondary lipid variables for assessment of ASCVD risk, the role of genetic testing in these disorders, as well as a discussion of the current and emergent treatment options, and their potential role in the management of dyslipidemias.

Basics of Lipid Metabolism

The 2 most clinically relevant plasma lipids are cholesterol and TGs (Fig. 1). Cholesterol's physiological roles include: (1) cell membrane constituent; (2) precursor for synthesis of steroid hormones, bile acids, and oxysterols; and (3) modifier of neuronal signalling molecules. TGs are an energy source for muscle and adipose tissue. Cholesterol and TGs circulate sequestered within the hydrophobic core of spherical lipoprotein particles, shielded from the aqueous plasma by surface phospholipids and apolipoproteins (1). Lipoprotein

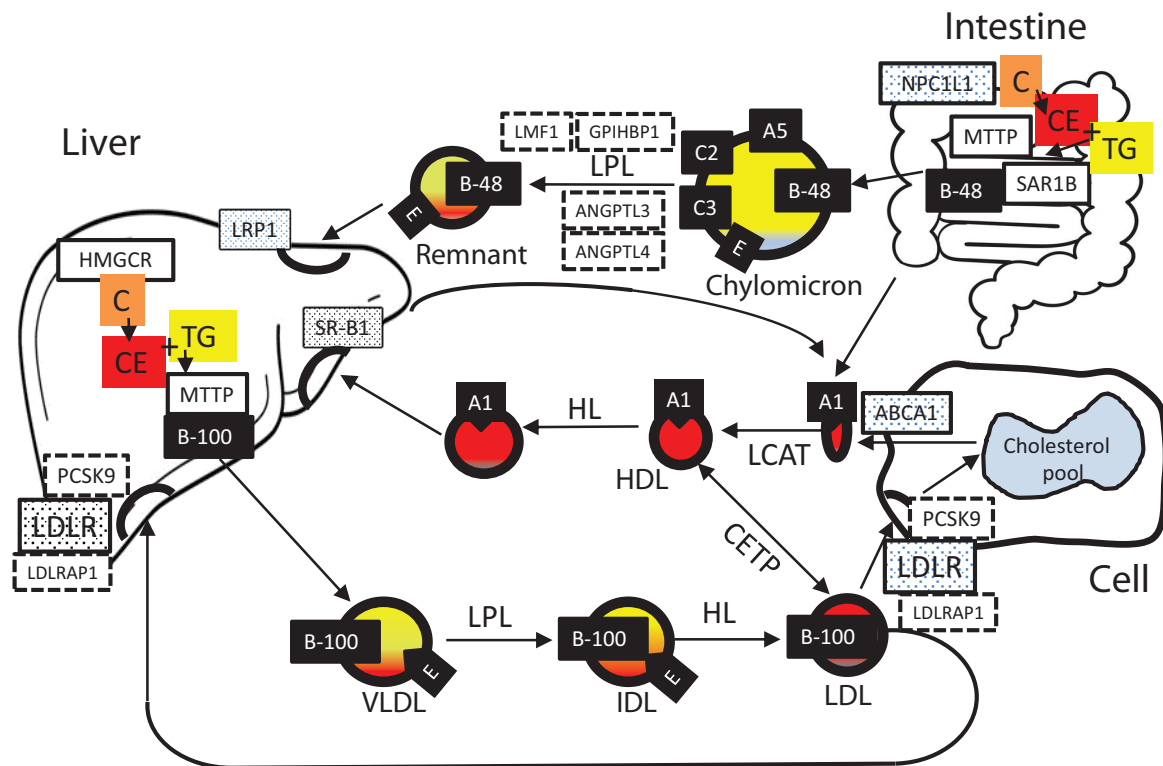

Figure 1. Schematic of plasma lipoprotein metabolism. See text for detailed explanation and abbreviations. Yellow, TG; red, cholesterol ester; orange, free cholesterol; black boxes, apolipoproteins; stippled boxes, receptors or transporters; dashed box borders, accessory proteins.

species, such as chylomicrons (CM), very low-density lipoprotein (VLDL), intermediate-density lipoprotein (IDL), LDL, and HDL are distinguished by features such as function, size, density, relative lipid content, and their defining apolipoproteins (1). The latter constituents provide stability to the particles, and can serve as ligands for receptors and as cofactors for processing and transporter molecules (1, 2).

Plasma cholesterol is primarily derived from hepatic synthesis (Fig. 1), with perhaps only 15% to 20% originating from the diet. Dietary cholesterol is absorbed by enterocytes in the upper small intestine via the Niemann-Pick C1-like 1 transporter (3). In the liver, cholesterol can be acquired from plasma by lipoprotein uptake or it can be synthesized *de novo* through a multistep process, for which the enzyme 3-hydroxy-3-methylglutaryl CoA reductase (HMGCR) is rate limiting (4). Hepatic free C is esterified for transit in lipoproteins in the form of cholesterol ester (CE) (5, 6).

Plasma TG originates from both dietary sources and hepatic synthesis (Fig. 1). Dietary fatty acids are taken up by enterocytic fatty acid transport proteins and are synthesized into TGs by a multistep process that includes diacylglycerol O-acyltransferase (7, 8). Packaging of TG and CE into nascent lipoproteins in both the intestine and liver requires microsomal triglyceride transfer protein (9, 10). In the intestine, the intracellular SAR1B GTPase protein encoded by the *SAR1B* gene is also essential for assembly of CM particles (11). Tissue-specific editing of *APOB* mRNA gives rise to intestinal apo B-48 and hepatic apo B-100, which are exclusive to CM and VLDL particles, respectively,

CMs contain ~90% TGs, with the remaining lipid comprising dietary free cholesterol. CMs traverse intestinal lymphatics and enter the circulation through the thoracic duct (6, 12). CMs are rapidly cleared from circulation via lipoprotein lipase (LPL)-mediated hydrolysis, with liberated fatty acids taken up by peripheral tissues. Intracellular LPL is escorted to the endothelial surface by lipase maturation factor 1 and is tethered by glycosylphosphatidylinositol-anchored HDL binding protein 1 (13). LPL's activity is enhanced by apo C-II and apo A-V, and inhibited by apo C-III (C3) and angiopoietin-like proteins 3 and 4 (ANGPTL3 and ANGPTL4) (12-14). TG-depleted chylomicron remnants are hepatically cleared by LDL receptor-related protein type 1 (15).

The principal lipoprotein synthesized and secreted by the liver is VLDL, which contains TG and CE/C in a 3 to 4:1 ratio together with a single defining apo B-100 molecule (12). TGs within circulating VLDL are hydrolyzed by LPL, yielding atherogenic remnant particles such as IDL, which contains roughly equal concentrations of TG and CE/C (6, 12). Additional cholesterol enrichment occurs after CE from HDL is exchanged for TG from apo B-containing

lipoproteins, a process mediated by cholesterol ester transfer protein (CETP) (16). Further TG depletion and CE enrichment by hepatic lipase (HL) generates LDL, which is ultimately cleared by hepatic LDL receptors (LDLRs), with assistance from LDLR adaptor protein 1 (LDLRAP1) (17). LDLRs are continuously recycled until they are targeted for degradation by proprotein convertase PCSK9 (18). CEs are broken down into free cholesterol by lysosomal acid lipase (19). Lp(a) has an independent metabolic itinerary (not shown).

HDL mediates reverse cholesterol transport from peripheral cells to the liver (20). Lipid-poor apo A-I (A1)-containing pre-beta HDL acquires cholesterol from peripheral cells via ATP binding cassette transporter A1 and after further processing by lecithin:cholesterol acyltransferase (LCAT) forms mature HDL (21). Circulating HDL is remodeled by HL and by the give and take of lipids mediated by CETP. HDL particles are endocytosed by scavenger receptor B1 (SR-B1) on hepatocytes, with cholesterol content directed towards secretion in bile (22-24).

Classifying dyslipidemias

The Frederickson (World Health Organization) classification of dyslipidemias was originally described in the 1960s and defined 5 categories of dyslipidemia (types 1-5) based on observable phenotypes and lipoprotein fractionation findings (25). Types 1 and 3 through 5 were primarily defined by elevated levels of various triglyceride-rich lipoprotein subfractions, with type 2 demonstrating elevation in LDL-C, either in isolation (type 2A) or in combination with elevated VLDL (type 2B) (25, 26). Although it was useful in the pre-molecular era, we believe it is time to dispense with this classification system. Because fractionation methods such as ultracentrifugation are inaccessible for most clinicians, accurate Frederickson phenotyping is not practical. Also, contrary to past beliefs, most Frederickson phenotypes are not monogenic, but rather have a polygenic basis. For these reasons, there is no further need to perpetuate this system as the basis for diagnosis and treatment of dyslipidemias.

We showed that 4 Frederickson phenotypes have an underlying polygenic basis (27-30), most often excessive accumulation of common TG-raising DNA variants. This pattern is seen in patients with combined hyperlipidemia (CHL; former type 2B) (31), mild-to-moderate isolated hypertriglyceridemia (HTG, former type 4) (32), and severe HTG (multifactorial chylomicronemia or former type 5) (33). Furthermore, we have observed that patients with dysbetalipoproteinemia (remnant disease or former type 3) also have an excess of common TG-raising alleles (R.A.H., unpublished data). Only FCS (former type 1) (34)

Table 1. Biochemical levels for dyslipidemia in adults >18 years of age

	LDL-C	TG	HDL-C
Mild-to-moderate deviation			
Levels	3.4-4.9 mmol/L 130-194 mg/dL	2-9.9 mmol/L 175-885 mg/dL	0.7-0.9 mmol/L 25-35 mg/dL
Etiology	Polygenic predisposition plus secondary factors (see Table 7)		
Severe deviation			
Levels	≥ 5.0 mmol/L ≥ 194 mg/dL	≥ 10 mmol/L ≥ 885 mg/dL	< 0.7 mmol/L < 25 mg/dL
Etiology	Monogenic disorders (see Table 4) and/or marked polygenic predisposition plus secondary factors (see Table 7)		

Abbreviations: HDL-C, high-density lipoprotein cholesterol; LDL-C, low-density lipoprotein cholesterol; TG, triglyceride.

and familial hypercholesterolemia (FH; a subtype of former type 2A) (35) are caused by rare pathogenic Mendelian variants, although at least one-third of patients with suspected FH have a high polygenic score for LDL-C (35). We recommend that the overall lipid disturbance obtained from the routine lipid panel—primary hypercholesterolemia, primary HTG, combined, or other—is a practical starting point for clinical algorithms (Table 1) (36).

Prevalence of dyslipidemia

Defining “hypercholesterolemia” depends on the clinical context. LDL-C is roughly normally distributed in the population, with a slight right-skew and a mean of approximately 2.6, 3.2, and 3.5 mmol/L (100, 124, and 135 mg/dL) and 2.9, 3.4, and 3.3 mmol/L (112, 132, and 138 mg/dL) for European women and men aged 20 to 39, 40 to 65, and 66 to 100 years, respectively (37). The 95th percentile roughly corresponds to an LDL-C value of 5.0 mmol/L (194 mg/dL).

Recommendations regarding who may benefit from lipid-lowering therapy depend on baseline risk of ASCVD. Lowering cholesterol is associated with a reduction in ASCVD risk, with a 20% relative risk reduction for every 1 mmol/L reduction in LDL-C (38, 39). LDL-C >95th percentile (ie, >5.0 mmol/L [194 mg/dL]) is generally the point at which one may consider a primary genetic disorder, and also the point at which treatment would be recommended regardless of age or other risk factors (40-44). Therefore, it is reasonable to define hypercholesterolemia as an LDL-C level >5.0 mmol/L (194 mg/dL).

However, this approach will not capture the majority of individuals who would benefit from treatment. Therefore, “hypercholesterolemia” may alternatively apply to an individual whose LDL-C exceeds the recommended threshold considering her or his baseline ASCVD risk. However, this definition is also problematic because there is no universally

accepted threshold or target cholesterol, as recommendations vary between guideline groups (41-44).

It may be reasonable to refer to the first situation, with LDL-C values >95th percentile as “severe hypercholesterolemia” and the second as merely “hypercholesterolemia,” but these definitions lack standardization and consensus.

HTG is perhaps more easily defined because it has a markedly right-skewed population distribution, with an extended right tail representing extreme TG phenotypes (1). The 95th percentile for TG is >3.37 mmol/L (>300 mg/dL), with the 99th percentile at ~5.0 mmol/L (~440 mg/dL) (37). Most laboratories report the upper limit of normal for TG as >1.7 mmol/L (>150 mg/dL), which is at ~75th percentile. Various societies have set different TG intervals to define HTG as either “mild,” “moderate,” or “severe” (45-47). Severe HTG is often defined as TG >10 mmol/L (>885 mg/dL) in SI-based jurisdictions and >1000 mg/dL (>11.1 mmol/L) in jurisdictions using conventional units. HTG in the range occurs in ~1 in 500 individuals (46) and signals the presence of chylomicrons within the serum (12).

The population distribution of HDL-C also shows a slightly right-skewed distribution. Mean HDL-C is 1.6, 1.7, and 1.9 mmol/L (62, 66, and 74 mg/dL) and 1.2, 1.3, and 1.5 mmol/L (46, 50, and 58 mg/dL) for European women and men aged 20 to 39, 40 to 65, and 66 to 100 years, respectively (37). The 2.5th percentile for low HDL-C is 0.7 and 0.9 mmol/L (27 and 35 mg/dL) for European men and women, respectively (37). ASCVD risk is inversely correlated with circulating levels of HDL-C; a level <0.9 mmol/L (<35 mg/dL) is identified as an independent ASCVD risk factor (48), although a direct causal role has not been established.

It is important to note that there is significant ethnic variation in distribution of TG and HDL-C values, which should be taken into consideration when interpreting the lipid profile (49, 50).

Lp(a) follows a population pattern of distribution similar to that of TGs, with a skewed normal distribution with a large right tail. Mean Lp(a) in European adults is 19 nmol/L (10.5 mg/dL), with the 80th percentile being a level of 87.3 nmol/L (41.8 mg/dL) (51). Higher concentration distributions are seen in individuals of African descent than in individuals of Caucasian or Asian ethnicity (51).

Clinical consequences

Lipoproteins and ASCVD. A direct causal role for LDL particles and LDL-C in the pathogenesis of ASCVD is well-established, with increasing risk seen with elevated LDL-C (52, 53). Excessive numbers of plasma LDL particles, especially after these undergo modifications such as oxidation, are taken up by scavenger receptors on arterial wall macrophages, generating foam cells that are the foundation of atherosclerotic plaques (54). Oxidation of LDL within the arterial wall also leads to production of cytokine signals and recruitment of inflammatory cells, which further contributes to atherogenesis (55-57). An occlusive vascular event may occur when a plaque ruptures, leading to myocardial infarction, stroke, or peripheral limb ischemia (57).

In contrast, a direct role of HDL in mediating ASCVD is uncertain. From epidemiologic studies, low HDL-C is an independent ASCVD risk factor (58). The TC:HDL-C ratio, which is mirrored by the apo B:A-I ratio (59), is more predictive of ASCVD risk than either component of the ratio, indirectly suggesting a role for low HDL-C in ASCVD (60). However, many individuals with isolated low HDL-C resulting from genetic variants show no increased tendency toward ASCVD (61). Also, HDL-C-raising therapies have failed to demonstrate ASCVD benefit (62, 63).

The role of TG in predisposing to ASCVD risk is less controversial. A direct relationship is challenging to discern because elevated TG is often associated with depressed HDL-C (64). Analyses that have adjusted for confounding factors have largely concluded that elevated TG is an independent risk factor for ASCVD; this is especially true for nonfasting TG levels (65-68). Furthermore, Mendelian randomization experiments that attempted to evaluate genetic risk for HTG in isolation have also shown an association with ASCVD (69, 70).

As a pathogenic factor, TGs may not contribute to atherogenesis directly. Instead, the CE content of TG-rich lipoproteins and their remnant particles, such as IDL, CMR, and VLDL remnants, is considered to be the likely culprit (71, 72). CMs are not considered atherogenic because of their size, which limits their penetration of the arterial wall (73). Atherosclerotic plaques do not contain TGs but rather CE, which is derived from TG-rich apo B-containing

lipoproteins that can enter the subintimal space (74-76). It is hypothesized that patients with increased levels of VLDL are prone to accumulate small, dense LDL (sdLDL) particles, which may be better able to infiltrate the arterial wall, and promote more atherosclerosis (77, 78). Also, elevated TG may indirectly affect such pro-atherogenic mechanisms as inflammation, thrombogenesis, cellular proliferation, and abnormal endothelial function (79).

Other clinical manifestations in dyslipidemia

Although ASCVD prevention is of paramount importance, dyslipidemia is associated with other clinical issues for which preventive therapies are required. The most clinically relevant is the causal relationship between severe HTG (ie, TG >10 mmol/L or >885 mg/dL) and the development of acute pancreatitis (45). Although the underlying pathophysiology is not understood, it could be related to abnormal lipolysis by mislocalized exocrine pancreatic lipase, leading to pancreatic autodigestion and inflammation (80). Also, monogenic dyslipidemias can present with multisystem involvement, as discussed later.

Screening for dyslipidemia

Pediatric screening. Atherosclerosis begins in childhood (81-83), and early medical intervention particularly among children with FH is currently advised by many opinion leaders to reduce long-term ASCVD risk (84-87). There is no clear consensus regarding whom to screen for dyslipidemia and when. Some guidelines suggest universal screening should be undertaken in all children, with the rationale that early identification and treatment of pediatric dyslipidemias, mainly FH, will reduce ASCVD risk (Table 2). A universal screening program for FH at birth showed that 8 patients (4 children and 4 parents) were newly identified for every 1000 infants screened, which was regarded as a cost-effective approach (88). By contrast, a targeted approach to screen only individuals with a family history of lipid disorders or premature ASCVD failed to identify up to 60% of at-risk children (89-91), although some have argued that targeting only children with a positive family history is a maximally cost-effective approach (92). At the very least, a family history of an extreme lipid phenotype or premature ASCVD should prompt consideration of cascade screening in children.

One example of universal screening recommendations is: (1) screen once between ages 9 and 11 years; and (2) again once between ages 17 and 21 years (42, 89, 93) (Table 2). Because lipid levels can be dynamic during puberty, screening from ages of 12 to 16 years could be misleading.

Table 2. Screening for dyslipidemia

	CCS	EAS/ESC	ACC/AHA/NECP/ ATP III	USPSTF	NHLBI/NLA
Males, age (y)	> 40	>40	>20	>35	Age 9-11 and Age 20
Females, age (y)	> 40 (or postmenopausal)	>50 (or postmenopausal)	>20	>45	
Special populations	Screen at time of identification of risk factors	Children with suspected FH		20-35 y (male) 20-45 y (female) if risk factors for ASCVD	>2 if family history of premature ASCVD or FH or ASCVD risk factors
How to screen	Standard fasting or nonfasting lipid profile: TC, LDL-C, HDL-C, non-HDL-C, TG Lp(a) – once in patient's lifetime, with initial screening Optional: apo B	Standard fasting or nonfasting lipid profile: TC, LDL-C, HDL-C, non-HDL-C, TG apo B Lp(a): consider once in patient's lifetime	Standard fasting or nonfasting lipid profile: TC, LDL-C, HDL-C, non-HDL-C, TG Optional: apo B Lp(a)	Standard fasting or nonfasting lipid profile: TC, LDL-C, HDL-C, non-HDL-C, TG	Standard fasting or nonfasting lipid profile: TC, LDL-C, HDL-C, non-HDL-C, TG

Abbreviations: ACC, American College of Cardiology; AHA, American Heart Association; apo B, apolipoprotein B; ASCVD, atherosclerotic cardiovascular disease; ATP, Adult Treatment Panel; CCS, Canadian Cardiovascular Society; EAS, European Atherosclerosis Society; ESC, European Society of Cardiology; FH, familial hypercholesterolemia; Lp(a), lipoprotein(a); NECP, National Cholesterol Education Program; NHLBI, National Heart, Lung, and Blood Institute; NLA, National Lipid Association; USPSTF, US Preventative Services Task Force; TC, total cholesterol; TG, triglyceride.

For children with ASCVD risk factors or family history of FH or severe hypercholesterolemia, screening earlier or more frequently may be warranted. Prospective longer term follow-up is needed.

Adult screening. Screening recommendations in adults similarly suffer from lack of consensus. Some guidelines argue against universal screening in individuals without risk factors until at least age 40 years (43, 94) (Table 2). Other guidelines suggest screening all adults beginning at age 20 years, or when they first enter a general practitioner's care, and then again from ages 25 to 30 and 30 to 35 years for higher risk males and females, respectively (42, 47), or age 35 or 45 years for lower risk males and females, respectively (95, 96) (Table 2). The rationale behind identifying dyslipidemias in younger adults is to allow for earlier interventions, mainly for those with elevated LDL-C, to reduce the lifetime ASCVD risk. The effectiveness of early and aggressive treatment to reduce ASCVD events in higher risk individuals has been well-established (97–99).

What is the best screening test?

Most guidelines suggest using a standard fasting or nonfasting lipid profile that includes total cholesterol (TC), LDL-C, HDL-C, non-HDL-C, and TG as the screening test of choice (42–44, 58). With TG >4.5 mmol/L (>400 mg/

dL), a repeat fasting lipid profile is preferred. Some guidelines also suggest routine measurement of apo B (ie, liver-derived apo B-100) as a superior indicator of ASCVD risk because it integrates all atherogenic lipoprotein particles including VLDL, LDL, IDL, remnants, and Lp(a) (43, 44). Measurement of Lp(a) once in an individual's lifetime is also recommended in some guidelines to further refine risk stratification (43, 44).

A standard serum lipid profile directly measures the concentration of total and HDL cholesterol and TG level. LDL-C is then estimated using the Friedewald equation, which calculates LDL by taking the directly measured total cholesterol and subtracting VLDL-C (estimated by dividing measured TG by 2.2 in mmol/L or 5 in mg/dL) and subtracting HDL-C (100). This formula is invalid when TG levels are > 4.5 mmol/L (>400 mg/dL) and may underestimate LDL-C at low levels (< 0.6 mmol/L/< 23 mg/dL). It may also underestimate the atherogenic burden of cholesterol from IDL and VLDL remnants. It is also unable to provide details on the number or size of atherogenic particles, which may miss a high burden of sdLDL (101). Direct measurement of LDL is also possible and can be considered in individuals with TG levels >4.5 mmol/L (>400 mg/dL); however, these values may differ substantially from calculated values and most treatment guidelines and clinical trials have used calculated LDL-C as their primary measure.

Individuals with insulin resistance (eg, with obesity, type 2 diabetes) tend to have a higher burden of sdLDL (101, 102). Because higher LDL particle number has been linked with increased ASCVD risk, independent of other lipid markers, conventional measurement may underestimate risk in these individuals (103). Certain methods can provide information on lipoprotein subclasses, size, and particle number, such as nuclear magnetic resonance spectroscopy, gradient gel electrophoresis, analytical ultracentrifugation, and ion mobility, although these are not widely available, not standardized, and their clinical utility is not yet established (104). More research is needed to determine their role in guiding risk stratification.

Non-HDL-C is a simpler way to estimate atherogenic lipoprotein levels in patients with elevated TG. This is calculated by subtracting directly measured HDL-C from TC. It comprises cholesterol present in all atherogenic lipoproteins including LDL, IDL, VLDL, Lp(a), and remnants, and may provide a better estimate of overall atherogenic risk than LDL-C (105).

Alternatively, direct measurement of apo B will also provide information on the number of atherogenic lipoprotein particles present, and is also associated with ASCVD risk (43, 106). Availability is variable, and global standardization is still lacking but this measure may similarly provide a better estimate of risk in those with insulin resistance states or HTG, and may help guide treatment decisions in those with borderline findings on a standard lipid profile.

A lipid profile may be less accurate in the setting of high circulating levels of pathological monoclonal proteins (107), and following an acute coronary syndrome (ACS) event, surgery, or injury. Lower LDL-C and HDL-C and higher TG levels have been observed 24 to 96 hours following ACS and persisting up to 2 months following the event, perhaps related to stress-induced myocardial injury (108-110). In the past, some clinicians have refrained from making treatment decisions based on lipids measured in the peri-ACS time period; however, clinical trials and clinical experience have since proven that such values are still informative.

Testing concerns and limitations

Potential sources of error when obtaining a standard lipid profile include artefacts from elevated TG or nonfasting. For the majority of patients screened without HTG, a nonfasting profile provides an accurate estimate—to within <5% error—of LDL-C (111). The most common method used for reported LDL-C values is the calculated LDL-C from the Friedewald formula, which becomes particularly inaccurate when TG >4.5 mmol/L (>400 mg/dL) (112). Below this value, the confounding by TG is considered clinically acceptable (113).

In contrast, methods for directly measured LDL-C are expensive and not widely available or standardized.

Non-HDL-C is considered to be reliable, predictive of ASCVD risk, and less prone to artifacts from elevated TG or nonfasting (114), as is apo B determination, although it requires additional infrastructure incurring additional cost (115). However, some opinion leaders argue that non-HDL-C should not replace LDL-C in clinical decision making (116).

Two newer algorithms for LDL-C determination from standard laboratory chemistry, namely the Martin-Hopkins equation (117) and the Sampson-NIH equation (118), have both been shown to be superior to common Friedewald calculated LDL-C, especially when TGs are very high or when LDL-C is extremely low, as with patients taking new potent lipid-lowering medications. Finally, a standard lipid profile provides no details on the lipoprotein particle size (ie, sdLDL), which may be more atherogenic than larger subspecies (77). Currently, routinely evaluating lipoprotein particle size is not recommended, given lack of evidence that this can influence outcomes, the lack of standardization, and the additional expense (119). Furthermore, apo B level is a good predictor of LDL particle size (120). We recommend a nonfasting LDL-C determination by Friedewald or preferably the Sampson or related equation, with non HDL-C or apo B as alternatives. If TG >4.5 mmol/L (>400 mg/dL), it is reasonable to request a repeat fasting lipid profile.

Monitoring of lipid levels. There is no consensus on the best approach to monitor lipid profiles in patients before and during treatment. Generally, lipids should be assessed at least twice before starting drug therapy, and then repeated 8-12 weeks after initiation or dose adjustment (121) (Table 3). For individuals being treated for secondary prevention of ASCVD or higher risk primary prevention with LDL-C below treatment intensification thresholds, monitoring annually is reasonable. For low-risk primary ASCVD prevention individuals with LDL-C levels below treatment intensification thresholds, less frequent monitoring (ie, every 5 years) may be appropriate.

For biochemical monitoring for adverse effects of statins, we advocate that ALT and creatine kinase (CK) should be measured before starting treatment to obtain a baseline as a point of reference should future concerns arise; however, routine monitoring is generally unnecessary (122). Several studies have concluded that the rates of statin-induced elevations of aminotransferase levels are rare (123-125) and may not be significantly different than in the general population (122, 126). Statins are not contraindicated in individuals with mild baseline elevation in transaminases (<3× upper limit of normal [ULN]) or in those with nonalcoholic fatty liver disease, and these individuals do not seem to be at increased risk for statin hepatotoxicity (122, 127). Statins are, however, contraindicated in those with

Table 3. Laboratory assessment of patients with dyslipidemias

Baseline lipid evaluation

- Lipoprotein profile: TC, LDL-C, non-HDL-C and HDL-C, and TG
- Apolipoprotein B is desirable if accessible
- Lipoprotein(a) can be measured once in the patient's lifetime
- Optional/academic interest: lipoprotein particle size, remnant particle assay, cholesterol efflux assay for HDL function, apo A-I to allow calculation of apo B to A-I ratio

Screening for secondary causes

- Diabetes: fasting glucose, glycated hemoglobin
- Hypothyroidism: thyroid stimulating hormone
- Liver disease: transaminases, bilirubin, alkaline phosphatase, gamma glutamyl transferase
- Renal disease: serum creatinine, urinary albumin, albumin to creatinine ratio
- Autoimmune diseases: serum rheumatoid factor, antinuclear antigen, C-reactive protein

Associated abnormalities in monogenic dyslipidemias

- Hematologic: abnormal erythrocyte morphology in low LDL-C states and LCAT deficiency
- Coagulation: prolonged international normalized ratio in low LDL-C states
- Serum fat-soluble vitamin levels: depressed in low LDL-C states
- Serum pancreatic lipase: elevated in hypertriglyceridemia-associated pancreatitis
- Cardiovascular: noninvasive imaging of premature atherosclerosis in coronary, extracranial carotid arteries, and peripheral arteries in several dyslipidemias
- Gastrointestinal and hepatic: abdominal ultrasound for fatty liver in low LDL-C states, hepatosplenomegaly in monogenic chylomicronemia

Diagnostic targeted sequencing panel or targeted exome for dyslipidemia genes

- Causative genes listed in Table 4

Specialized research lipid biochemistry (not essential; confirmatory or for academic interest)

- Serum or plasma plant sterols to confirm sitosterolemia
- Post-heparin plasma lipolytic assay to confirm lipoprotein lipase deficiency
- Serum or plasma lysosomal acid lipase to confirm lysosomal acid lipase deficiency
- Serum cholesterol efflux capacity in HDL-C deficiency states

Abbreviations: apo, apolipoprotein; HDL-C, high-density lipoprotein cholesterol; LCAT, lecithin cholesterol acyl transferase; LDL-C, low-density lipoprotein cholesterol; TC, total cholesterol; TG, triglyceride.

decompensated cirrhosis or acute liver failure. For those individuals with transaminase elevations $>3\times$ ULN, using a lower starting dose of statin and monitoring transaminases at 4- to 12-week intervals during cautious up-titration may be reasonable. A clinical approach to the patient with statin intolerance is discussed later.

If baseline CK is >5 times ULN, some would advise refraining from statin initiation and considering alternative therapy because CK may rise even higher when a statin is introduced. However, if a patient has no risk factors for myopathy, CK does not need to be routinely monitored. A clinical approach to the patient with statin intolerance is discussed in more detail later.

Rare Dyslipidemias

For any patient referred with severe dyslipidemia, rare monogenic causes must be considered and ruled out because these may require specialized diagnosis, intervention, and monitoring (128). Monogenic dyslipidemias are shown in Table 4, grouped by the primary lipid disturbance, causative gene, chromosomal location, and inheritance pattern. Corresponding clinical features are listed in

Tables 5 and 6. A detailed discussion is beyond the scope here; the interested reader is referred to a recent review (128). Here, we touch on a few generalities related to monogenic dyslipidemias.

Suspicion for a monogenic dyslipidemia (129) is raised by: (1) the degree of deviation of the lipid or lipoprotein trait (ie, a more extreme deviation means a monogenic etiology is more likely); (2) a younger age at presentation; (3) the detection of specific clinical features (see Tables 5 and 6, and Fig. 2); and (4) a known family history of dyslipidemia and/or early atherosclerosis; and 5) the absence of secondary factors (Table 7).

Table 4 shows a classification of 18 syndromic lipid disorders that result from rare pathogenic variants in 23 different genes. Some disorders result from variants in more than 1 gene, whereas in other cases different rare variants in the same gene cause different diseases. The monogenic disorders in Table 4 show classical Mendelian segregation patterns, usually autosomal recessive, in which both copies of the gene harbor pathogenic variants (ie, biallelic), which can be identical (ie, simple homozygote) or different (ie, compound heterozygote). The defining feature of a true recessive trait is that monoallelic individuals (ie, obligate heterozygotes for the pathogenic variant such as parents)

Table 4. Monogenic dyslipidemias: molecular genetics

Disorder	Gene/chromosome	Inheritance	MIM reference numbers
Group 1: Monogenic hypercholesterolemia			
Familial hypercholesterolemia	<i>LDLR</i> /19q13 <i>APOB</i> /2p24 <i>PCSK9</i> /1p32	ASD	143890, 143890, 606945, 144010, 615558, 107730, 603776, 607786
Autosomal recessive hypercholesterolemia	<i>LDLRAP1</i> /1p35	AR	603813, 605747
Sitosterolemia	<i>ABCG5</i> /2p21 <i>ABCG8</i> /2p21	AR	210250, 605459, 605460
Lysosomal acid lipase deficiency	<i>LIPA</i> /10q23	AR	278000, 613497
Group 2: Monogenic hypocholesterolemia			
Abetalipoproteinemia	<i>MTTP</i> /4q23	AR	20010, 157147
Hypobetalipoproteinemia	<i>APOB</i> /2p24	ASD	144010, 615558, 107730
Chylomicron retention (Anderson) disease	<i>SAR1B</i> /5q31	AR	246700, 607690
Familial combined hypolipidemia	<i>ANGPTL3</i> /1p31	AR	605019, 604774
PCSK9 deficiency	<i>PCSK9</i> /1p32	ASD	605019, 613589, 607786
Group 2A: Monogenic hyperalphalipoproteinemia			
CETP deficiency	<i>CETP</i> /16q13	ASD	143470, 118470
Hepatic lipase deficiency	<i>LIPC</i> /15q21	AR	614025, 151670
Scavenger receptor B1 deficiency	<i>SCARB1</i> /12q24	ASD	610762, 601040
Group 2B: Monogenic hypoalphalipoproteinemia			
Familial hypoalphalipoproteinemia	<i>APOA1</i> /11q23	ASD	604091
Tangier disease	<i>ABCA1</i> /9q31	ASD	205400
Familial LCAT deficiency	<i>LCAT</i> /16q22	AR	245900
Group 3A: Monogenic hypertriglyceridemia			
Familial chylomicronemia syndrome	<i>LPL</i> /8p22 <i>APOC2</i> /19q13 <i>APOA5</i> /11q23 <i>LMF1</i> /16p13 <i>GPIHBP1</i> /8q24	AR	609708, 238600 207750, 608083 145750, 144650, 606368 246650, 611761 612757
Infantile HTG, transient	<i>GPD1</i> /12q12	AR	614480
Dysbetalipoproteinemia	<i>APOE</i> /19q13	AR ^a	618347
Secondary hereditary dyslipidemias			
Partial lipodystrophies	<i>LMNA</i> /1q22 <i>PPARG</i> /3p25.2 <i>PLIN1</i> /15p26.1 <i>CIDECA</i> /3p25.3	AD AD AD AR	151660 604367 613877 615238
Generalized lipodystrophies	<i>AGPAT2</i> /9q34.3 <i>BSCL2</i> /11q12.3 <i>CAV1</i> /7q31.2 <i>CAVIN1</i> /17q21.2	AR AR AR AR	608594 269700 612526 613327

Abbreviations: ABCA1, gene encoding ATP-binding cassette protein type A1; ABCG5, gene encoding ATP-binding cassette protein type G5; ABCG8, gene encoding ATP-binding cassette protein type G8; ASD, autosomal semidominant (meaning that heterozygotes express an abnormal phenotype about half as extreme as homozygotes); AD, autosomal dominant; apo, apolipoprotein; AGPAT2, gene encoding 1-acylglycerol-3-phosphate O-acyltransferase 2; ANGPTL3, gene encoding angiopoietin like protein 3; APOA1, gene encoding apolipoprotein A1; APOA5, gene encoding apolipoprotein (apo) A-V; APOB, gene encoding apolipoprotein B; APOC2, gene encoding apo C-II; APOE, gene encoding apolipoprotein E; AR, autosomal recessive; BSCL2 gene encoding BSCL2 (seipin); CAV1 gene encoding caveolin 1; CAVIN1 gene encoding caveolae-associated protein 1; Chr, chromosomal location; CETP, gene encoding cholesterol ester transfer protein; CIDECA gene encoding cell death-inducing DFFA-like effector C; GPD1, gene encoding glycerol-3-phosphate dehydrogenase 1; GPIHBP1, glycosylphosphatidylinositol-anchored high-density lipoprotein-binding protein 1; GPIHBP1, gene encoding glycosylphosphatidylinositol-anchored HDL-binding protein 1; HDL-C, high-density lipoprotein cholesterol; HLP, hyperlipoproteinemia; LAL, lysosomal acid lipase; LCAT, gene encoding lecithin cholesterol acyl transferase; LDL-C, low-density lipoprotein cholesterol; LDLR, gene encoding the low-density lipoprotein receptor; LDLRAP1, gene encoding low-density lipoprotein receptor adapter adaptor protein 1; LIPA, gene encoding lysosomal acid lipase; LIPC, gene encoding hepatic lipase; LPL, lipoprotein lipase; LMNA, gene encoding lamin A; LPL, gene encoding LPL; LMF1, gene encoding lipase maturation factor 1; MIM, Mendelian Inheritance in Man; MTTP, gene encoding microsomal triglyceride transfer protein; NGS, next-generation sequencing; PCSK9, gene encoding the enzyme proprotein convertase subtilisin/kexin type 9; PLIN1, gene encoding perilipin 1; PPARG, gene encoding peroxisome proliferator-activated receptor-gamma; SAR1B, gene encoding GTP-binding protein SAR1b; SCARB1, gene encoding scavenger receptor 1B; TG, triglyceride.

^aSusceptibility to.

Table 5. Monogenic dyslipidemias: clinical features

Condition	Clinical features and comorbidities	Comments
Group 1: Monogenic hypercholesterolemia: severely elevated LDL-C		
Familial hypercholesterolemia	Xanthomas: tendinous (mainly) rarely periosteal, intracranial, peripatellar, digital web spaces Xanthelasmas, corneal arcus Early ASCVD: angina, acute coronary syndrome, myocardial infarction, stroke, transient ischemic attack, peripheral arterial disease, claudication, arterial bruits Aortic valve disease	HDL-C can be depressed; Lp(a) can be very elevated; Untreated biallelic (ie, homozygous) form can express clinical features in childhood while monoallelic (ie, heterozygous) form expresses clinical features in early adulthood
Autosomal recessive hypercholesterolemia	As above	Parents have normal lipids Affected children are indistinguishable from homozygous FH
Sitosterolemia	Xanthomas: tendinous, cutaneous, tuberous Splenomegaly Early ASCVD: angina, myocardial infarction, stroke, transient ischemic attack, claudication, arterial bruits Hemolysis/ hemolytic anemia Impaired platelet aggregation with easy bruising or bleeding	↑ plasma beta-sitosterol, campesterol stigmasterol are diagnostic, as is positive genetic sequencing showing biallelic mutations
Lysosomal acid lipase deficiency	Nausea, vomiting, diarrhea/steatorrhea Protuberant abdomen Hepatosplenomegaly, hepatic fibrosis, cirrhosis Xanthomatous infiltration of adrenal, spleen, lymph nodes, bone marrow, small intestine, lungs, and thymus	↑ TG frequently Transaminase elevations Lipid infiltration of liver is cholesterol not TG Calcified adrenal gland on imaging Aliases: Wolman syndrome in infants and cholesterol ester storage disease (somewhat milder presentation)
Group 2: Monogenic hypocholesterolemia		
Abetalipoproteinemia	Failure to thrive, steatorrhea Night blindness, atypical retinitis pigmentosa, retinal degeneration Osteomalacia, osteoporosis Ataxia, peripheral neuropathy, posterior column signs, deep tendon reflex loss	Acanthocytosis on peripheral blood smear Complete absence of apo B containing lipoproteins; HDL-C normal Undetectable levels of fat-soluble vitamins
Hypobetalipoproteinemia	Biallelic (ie, homozygous) form is clinically identical to abetalipoproteinemia	Monoallelic (ie, heterozygous) form has mainly biochemical features (ie, low but not absent apo B-containing lipoproteins) plus susceptibility to fatty liver (typical hepatosteatosis) and protection from ACSCVD
Chylomicron retention (Anderson) disease	Similar to abetalipoproteinemia Systemic features are less severe; no erythrocyte abnormalities	Distinguished biochemically from abetalipoproteinemia and homozygous hypobetalipoproteinemia by normal TG levels
Familial combined hypolipidemia	No defining clinical features Probable protection from ASCVD	Biallelic form: profound deficiency of all lipoproteins Monoallelic form: normal HDL-C; low apo B-containing lipoproteins
Group 2A: Monogenic hyperalphalipoproteinemia: extremely elevated HDL-C		
CETP deficiency	No defining clinical features Possible protection from ASCVD, although this is controversial	Biallelic form: extreme high HDL-C Monoallelic form: moderately elevated HDL-C
Hepatic lipase deficiency	Associated with accelerated ASCVD	Increases in both HDL-C and apo B-containing lipoproteins;
SR-B1 deficiency	Eruptive or palmar xanthomas sometimes No defining clinical features Possible protection from ASCVD, although this is controversial	Managed according to LDL-C targets Biallelic form: extremely high HDL-C Monoallelic form: moderately elevated HDL-C

Table 5. Continued

Condition	Clinical features and comorbidities	Comments
Group 2B: Monogenic hypoalphalipoproteinemia: severely depressed HDL-C		
Apolipoprotein A-I deficiency (familial hypoalphalipoproteinemia)	Xanthomatosis: cutaneous, interdigital web spaces Predisposition to early ASCVD	Biallelic form: absent HDL-C and apo A-I Monoallelic form: moderately depressed HDL-C and apo A-I
Tangier disease	Hepatosplenomegaly Corneal opacities Enlarged orange tonsils Dry/brittle skin/hair/nails CE deposition in lymph nodes, bone marrow, liver, spleen, tonsils Demyelinating sensory, autonomic, and motor neuropathies Often premature coronary disease, angina, carotid bruits, claudication	Biallelic form: absent HDL-C and apo A-I with clinical features plus stomatocytes on peripheral blood film Monoallelic form: moderately depressed HDL-C and apo A-I with no clinical features
Familial LCAT deficiency	Corneal lipid deposits and opacities Foam cells in bone marrow and renal glomeruli Proteinuria, renal failure Anemia	Low HDL-C, plasma esterified cholesterol, apo A-I and A-II High plasma free cholesterol, TG, Alias: fish eye disease for severe LCAT deficiency
Group 3A: Monogenic hypertriglyceridemia: severely elevated TG		
Familial chylomicronemia syndrome	Nausea, vomiting, failure to thrive, abdominal pain, pancreatitis risk Lipemic plasma Hepatosplenomegaly, lipemia retinalis, eruptive xanthomas, jaundice	Biallelic form is associated with early onset (often childhood) Relatives with mono-allelic form express extremely heterogeneous phenotypes ranging from normal TG to severe HTG
Infantile HTG, transient	Short stature Hepatosplenomegaly Hepatic steatosis/fibrosis	Elevated TG ± cholesterol and liver enzymes normalize with age High urinary dicarboxylic acid
Dysbetalipoproteinemia	Tuberoeruptive xanthomas, palmar crease xanthomas Premature atherosclerosis	Remnant lipoproteins, termed IDL and beta-VLDL, persist abnormally APOE E2/E2 homozygotes are predisposed but expression requires a second genetic abnormality
Secondary dyslipidemias		
Partial lipodystrophies	Distinctive patterns of regional lipodystrophy associated with simultaneous lipohypertrophy in unaffected areas Insulin resistance Recurrent pancreatitis	Elevated TG which can be severe in 10%-20% of cases
Generalized lipodystrophies	Absence of subcutaneous fat in subcutaneous tissues Insulin resistance Recurrent pancreatitis Hepatosplenomegaly	Elevated TG, which can be severe in majority of cases Elevated liver enzymes

Abbreviations: apo, apolipoprotein; ASCVD, atherosclerotic cardiovascular disease; CE, cholesterol ester; E2, binding defective isoform of apo E; FH, familial hypercholesterolemia; HDL-C, high-density lipoprotein cholesterol; HTG, hypertriglyceridemia; IDL, intermediate-density lipoprotein; LCAT, lecithin:cholesterol acyltransferase; LDL-C, low-density lipoprotein cholesterol; Lp(a), lipoprotein(a); TG, triglyceride; TTG, ; VLDL, very low-density lipoprotein.

show no detectable phenotype either clinically or biochemically and are referred to as “carriers.”

However, in one-third of monogenic dyslipidemias, an additive effect of pathogenic variants is observed clinically.

In these conditions, of which FH is the most familiar example (130), individuals with a single monoallelic variant (ie, heterozygotes) have a less severe phenotype than individuals with biallelic variants. In the past, this additive effect

Table 6. Dyslipidemias clinical summary

	Dermatologic	Cardiovascular	Gastrointestinal	Eye	Laboratory findings	Genetic influences	Secondary causes
High cholesterol states	Tendon xanthomas	Premature ASCVD Carotid bruits Femoral bruits		Xanthelasmas Corneal arcus	↑ TC, LDL-C	Single gene, autosomal semidominant: <i>LDLR</i> , <i>APOB</i> , <i>PCSK9</i> Single gene, autosomal recessive: <i>LDLRAP1</i> Other syndromes: Wolman (<i>LIPA</i>) Sitosterolemia (<i>ABCG5/ABCG8</i>) Polygenic	Hypothyroidism Cholestatic liver disease Nephrotic syndrome
High triglyceride states	Eruptive xanthomas Tuberoeruptive xanthomas ^a Palmar xanthomas ^a	Increased ASCVD risk	Pancreatitis Recurrent abdominal pain	Lipemia retinalis	↑ TC, TG	Single gene, recessive: <i>LPL</i> , <i>APOC2</i> , <i>APOA5</i> , <i>LMF1</i> , <i>GPIHBP1</i> Single gene, recessive, susceptibility: <i>APOE</i> Polygenic	Uncontrolled diabetes Hypothyroidism Obesity Alcohol Medications: OCP Retinoic acid BAS Steroids
Low HDL states		Variably increased ASCVD risk			↓ HDL-C	Single gene, recessive: <i>ABCA1</i> , <i>APOA1</i> , <i>LCAT</i> Single gene, semidominant: <i>ABCA1</i> Polygenic	Metabolic syndrome Obesity
Combined hyperlipidemia		Increased ASCVD risk			↑ TC, LDL-C, TG (also ↓ HDL-C)	Polygenic	Same as high cholesterol and TG states
Lipoprotein(a)		Increased ASCVD risk			↑ Lp (a)	<i>LPA</i> gene size polymorphism and SNPs	None

Abbreviations: ASCVD, atherosclerotic cardiovascular disease; BAS, bile acid sequestrants; HDL-C, high-density lipoprotein cholesterol; LDL-C, low-density lipoprotein cholesterol; OCP, oral contraceptive pill; SNPs, single nucleotide polymorphisms; TC, total cholesterol; TG, triglyceride.

^aIn familial dysbetalipoproteinemia.

was described using the term “codominant” inheritance, but now the newer term “semidominant” or “incomplete dominant” has been proposed for FH (131). In semidominant inheritance, heterozygotes display an abnormal biochemical phenotype sometimes with characteristic clinical features (Table 5). In individuals with biallelic mutations (ie, FH “homozygotes”), the LDL-C deviation is more extreme and clinical features typically become apparent at a young age (132). Because most practitioners will never encounter a case of ultrarare biallelic FH, but do commonly encounter monoallelic FH, FH reduces to apparently autosomal dominant genetics, an approximation that works well for all practical purposes (130).

Other monogenic dyslipidemias also show semidominant inheritance, including hypobetalipoproteinemia and Tangier disease. In these conditions, the heterozygote typically has a biochemical disturbance of intermediate severity, whereas the homozygote shows an extreme biochemical deviation often together with clinical findings (see Fig. 2) (133). In these situations, the monoallelic heterozygotes cannot be called “carriers” because they have an abnormal biochemical phenotype. Finding a clinical sign (Tables 5 and 6, and Fig. 2) is a noninvasive and cost-effective way to identify individuals with a monogenic dyslipidemia (134).

Secondary factors are less important in the clinical expression of monogenic disorders. Nonetheless, secondary

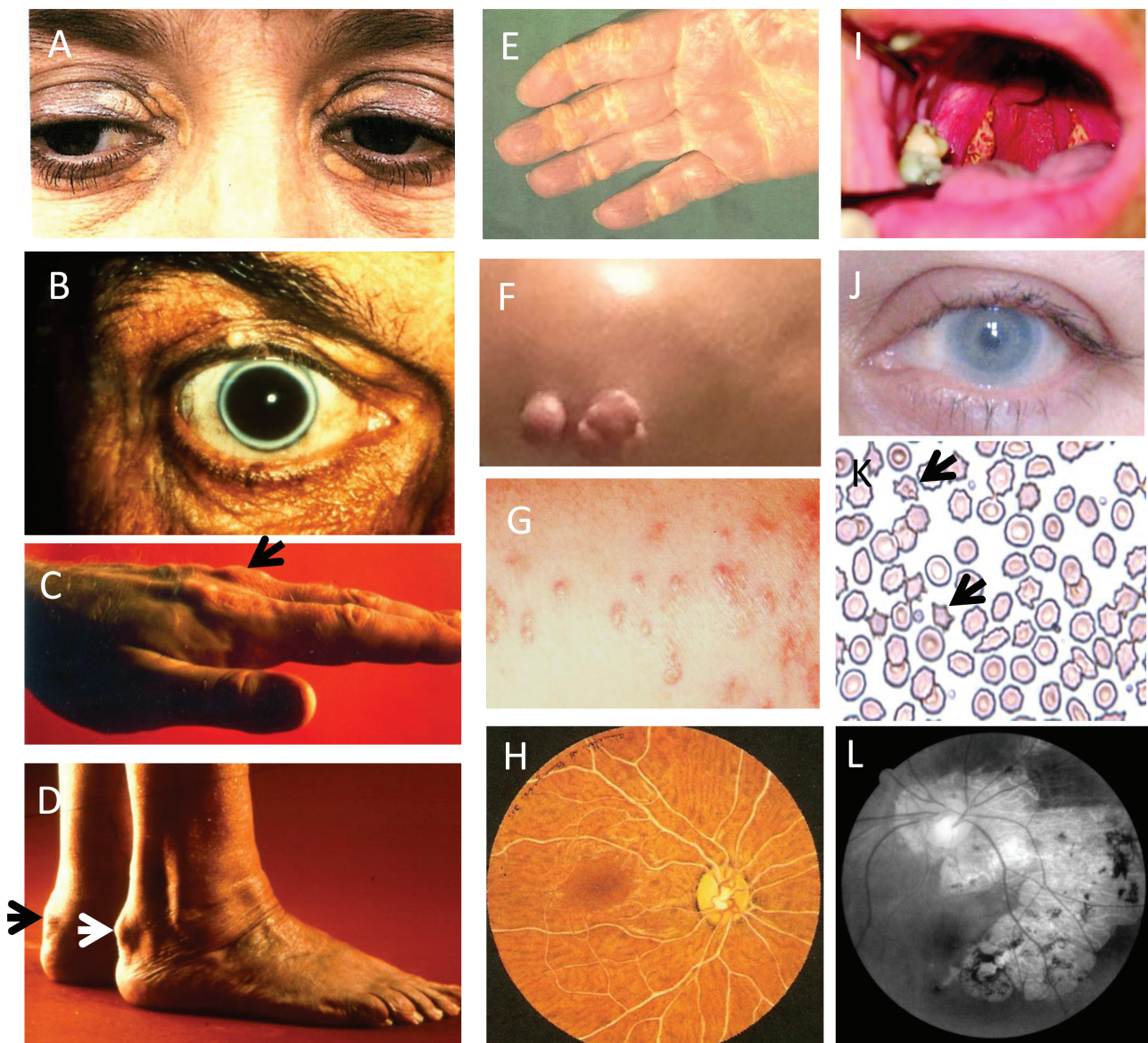

Figure 2. Physical manifestations of selected dyslipidemias. In untreated familial hypercholesterolemia (FH) findings include (A and B) xanthelasma; (B) arcus cornealis; (C and D) extensor tendon xanthomas, indicated by arrows. In untreated dysbetalipoproteinemia, findings include (E) palmar crease xanthomas and (F) tuberous xanthomas (here on elbow). In severe hypertriglyceridemia, manifestations can include (G) eruptive xanthomata and (H) lipemia retinalis. (I) Orange tonsils in Tangier disease (from Sampietro T, Puntoni M, Bigazzi F, et al. Tangier disease in severely progressive coronary and peripheral artery disease. *Circulation* 2009; 119: 2741-2742). (J) Corneal clouding in lecithin cholesterol acyl transferase deficiency. In abetalipoproteinemia, findings include (K) acanthocytes (indicated by arrows) on peripheral blood film and (L) atypical retinitis pigmentosa.

factors when present can worsen the clinical presentation and make treatment more difficult. Therefore, it is important to rule out secondary factors (see [Table 7](#)) even when a rare monogenic dyslipidemia has been diagnosed ([73](#), [132](#)).

Care for patients with rare dyslipidemias can be delivered in a specialized center (eg, one with apheresis for patients with biallelic FH). Specialty lipid clinics may also have advanced access to emerging therapies or are conducting clinical trials for these conditions. Care of patients with rare dyslipidemias should be the responsibility of an experienced individual, such as a certified lipidologist, endocrinologist, cardiologist, gastroenterologist, or primary care physician. Referral to subspecialties for baseline assessment and monitoring is

appropriate (eg, an ophthalmologist for abetalipoproteinemia or fish eye disease, a neurologist for abetalipoproteinemia or Tangier disease, an otolaryngologist for Tangier disease, and a nephrologist for LCAT deficiency). Children with a rare, severe dyslipidemia such as biallelic FH or FCS should receive care from a pediatrician with dyslipidemia expertise. Laboratory evaluation of patients with rare dyslipidemias is shown in [Table 3](#).

Role of genetic testing

When to consider genetic testing. Potential benefits of genetic testing include establishing a clear dyslipidemia

Table 7. Secondary lifestyle factors and medical conditions associated with dyslipidemia

	Associated primary lipid disturbance		
	↑ LDL-C	↑ TG	↓ HDL-C
Lifestyle			
Obesity	X	X	X
Physical inactivity	X	X	X
Excess alcohol		X	
Smoking			X
Dietary			
High trans fat	X		
High saturated fat	X		
High carbohydrate		X	X
Medical conditions			
Obstructive liver disease	X		
Hypothyroidism	X		
Nephrotic syndrome	X		
Anorexia	X		
Metabolic syndrome		X	X
Insulin resistance		X	X
Diabetes mellitus		X	X
Nonalcoholic fatty liver disease		X	X
Chronic renal failure		X	X
Cushing syndrome		X	X
HIV infection		X	X
Systemic lupus erythematosus		X	X
Lipodystrophy		X	X

Abbreviations: HDL-C, high-density lipoprotein cholesterol; LDL-C, low-density lipoprotein cholesterol; TG, triglyceride.

diagnosis, which eliminates uncertainty for both patient and provider and allows for more personalized management. This includes an improved understanding of overall prognosis and better selection of targeted pharmacological agents. Another potential benefit of a genetic diagnosis includes the ability to screen for genetic risk in family members who may be presymptomatic and could benefit from early intervention or increased monitoring (135).

The decision to proceed should be carefully considered. A young individual with a positive family history and without apparent secondary factors whose laboratory results or clinical findings fall far outside the normal range would particularly benefit. A reasonable threshold at which to consider genetic testing for FH would be LDL-C >5 mmol/L (>194 mg/dL), and for FCS would be TG >10 mmol/L (<885 mg/dL), in the absence of secondary causes. For rare dyslipidemias, this is best decided on a case-by-case basis, and referral to a specialist in genetics of lipid disorders would also be appropriate.

Types of genetic testing. We recently reviewed genetic testing methods for dyslipidemias, which include single gene

sequencing, targeted gene panels, whole exome, and whole genome sequencing (129). Gene panels that sequence regions known for dyslipidemia genes, such as those listed in Table 4, are currently the most common method. Advantages of gene panels include reasonable cost and turnover time. They have limited risk of detecting incidental findings unrelated to dyslipidemia. Gene panels can be designed to assay small-effect polymorphisms used to generate polygenic risk scores, which may show promise as an additional risk stratification tool, although standardization of such scores is lacking and their clinical utility currently remains unclear. Whole genome sequencing is becoming cost effective, and information regarding dyslipidemia genes can be pulled from these results using computer programs, although there is a risk of incidental findings because data from all other human disease genes have been obtained. Finally, as direct-to-consumer genetic testing becomes more common, practitioners may be increasingly called upon to interpret reports suggesting both monogenic and polygenic risk for lipid disorders. The prognostic value of these findings and is presently unknown; currently, these commercial offerings have an unacceptably high rate of both false-positive and false-negative calls even in monogenic disorders such as FH (134). A pragmatic approach for now would be to discuss the limitations of such testing with the patient, and in the case of an apparent positive result, to repeat the testing in a clinically accredited laboratory.

The National Lipid Association has published guidance for genetic testing in dyslipidemias (134). The recommendations include: (1) DNA testing has clinical utility when FH, FCS, and rare monogenic dyslipidemias are suspected; (2) clinical indications for most other dyslipidemic patients are not established; (3) a shared decision-making model between patient and provider is essential; (4) patient values and preferences are crucial; (5) testing should be done in an accredited laboratory; (6) results should be interpreted with caution and conveyed to the patient by an experienced provider; and (7) genetic counsellors can play an important role.

Genetic counselling. Counselling is an important piece of the genetic testing process. Pretest counselling should include a discussion of the objectives, risks, benefits, limitations, and clinical implications of the test result for the patient and family members. Posttest counselling should focus on the potential clinical significance of the findings for the patient and family members, including associated risks, personalized screening, and treatment recommendations. Individuals with unclear findings such as a DNA variant of undetermined significance should be counselled on the inconclusive nature of their results and the potential for a revision of the assigned pathogenicity of the variant as a result of future research.

High Cholesterol States

Clinical consequences/manifestations

Although heterozygous FH is not rare and deserves special attention, patients with FH are still a minority of those with high LDL-C; for most individuals with hypercholesterolemia, the only manifestation will be elevated LDL-C on a lipid profile (Table 6). In some cases of FH, additional physical stigmata can be present, including xanthelasmas (136), corneal arcus, and tendon xanthomas (Table 6 and Fig. 2). These findings used to be more prevalent in individuals presenting with FH, but are much less common today, owing to earlier recognition and treatment initiation. Xanthelasmas sometimes recede following initiation of cholesterol-lowering therapy (137, 138), whereas corneal arcus does not typically regress with treatment. Presence of corneal arcus in an individual <45 years suggests the patient may have FH, but it is a nonspecific finding in the elderly. The Achilles tendon is most commonly affected in FH, but other extensor tendons (ie, those on the dorsal surfaces of the hands and feet) can also be affected (139). Initially, the Achilles tendon thickens laterally, then loses its concave contour, and without treatment enlarges becoming easily visible or palpable, with or without discomfort (140). On histology, these xanthomas consist of cholesterol and lipid-laden foam cells (139).

The most relevant clinical complication hypercholesterolemia is ASCVD. LDL-C directly leads to the formation of atherosclerotic plaques through their uptake into macrophages and the generation of foam cells (55-57, 141). There is also a direct correlation between cholesterol levels and ASCVD event risk, mainly coronary artery disease but also ischemic stroke and peripheral arterial disease; lower on-treatment LDL-C, however achieved, is associated with lower event rates, with no apparent lower limit at which benefit is lost (52, 53, 142).

Secondary causes

Secondary factors play a minor role in the determination of serum cholesterol levels but should be ruled out before starting pharmacologic interventions, or for new or acute elevations. These are listed in Table 7 and include cholestatic liver disease, nephrotic syndrome, and hypothyroidism as well as effects of certain medications (89).

Monogenic causes

Familial hypercholesterolemia. As discussed previously, FH is an autosomal semidominant condition: individuals with 1 copy of a pathogenic variant (ie, monoallelic or “heterozygotes”) have an abnormal phenotype that is

intermediate between individuals with normal genetics and those with 2 copies of a pathogenic variant (biallelic, often encompassed by the nonspecific term “homozygotes”). The monoallelic form of FH has a population prevalence of ~1 in 300 people, and the biallelic form having a population prevalence of ~1 in 300 000 to 400 000 people.

Untreated FH is associated with premature development of ASCVD predisposing to cardiovascular events, stroke, and peripheral limb ischemia (41, 132). Physical manifestations of FH include tendon or planter xanthomas, xanthelasmas, and corneal arcus in individuals <45 years, as discussed previously. Total and LDL-C levels in heterozygous FH are usually >95th percentile (ie, >6.5 and >5.0 mmol/L [>250 and >194 mg/dL], respectively) (132). Clinical manifestations in the rare biallelic form are more severe, with onset of ASCVD in childhood or adolescence if there has been no treatment, and stoichiometrically greater elevations in untreated total and LDL-C levels (ie, >12 and >10 mmol/L [>465 and >385 mg/dL], respectively) (143).

Three main genes are associated with FH include loss-of-function mutations in *LDLR* (85%-90% of cases), *LDLR*-binding defective variants in *APOB* (5%-10% of cases), as well as gain-of-function mutations in *PCSK9* (<1% of cases) (130). There is also a true rare autosomal recessive form of FH caused by homozygous loss-of-function mutations in *LDLRAP1* (130). Heterozygous individuals (eg, parents with 1 pathogenic *LDLRAP1* variant) have a normal lipid profile and are true “carriers” in the classical genetic sense, whereas those with biallelic variants have a full-blown homozygous FH phenotype with LDL-C >10 mmol/L (>385 mg/dL).

Polygenic basis of elevated cholesterol. Complex polygenic disease traits, including dyslipidemia, are common in adults. Although these traits are genetic, they are influenced by numerous common genetic variants detectable as single nucleotide polymorphisms (SNPs) that have individually small effects on the associated trait. Most individuals will have inherited a balanced quantity of SNP loci that raise and lower a lipid variable (eg, LDL-C). Polygenic traits do not follow classical patterns of inheritance in family pedigrees. Occasionally, by chance, an individual’s genome will show inheritance of an overabundance of variants that raise the trait. With polygenic hypercholesterolemia, a high burden of LDL-C-raising SNPs leads to LDL-C levels >95th percentile, mimicking the clinical presentation of monoallelic FH (130). In fact, polygenic inheritance is seen in up to 50% of patients referred to lipid clinics with suspected heterozygous FH (35, 130).

SNPs identified as contributing to elevated LDL-C levels can be incorporated into a risk score that estimates this polygenic burden in a given individual (144, 145).

Compared with those with monogenic causes of elevated cholesterol, those with polygenic hypercholesterolemia tend to have a milder phenotype, and cholesterol levels may be more influenced by environmental or secondary factors (146). Polygenic traits still cluster in families but the inheritance pattern is more complex and possible phenotypes among first-degree relatives are more varied than with a monogenic trait (147).

Investigations. Physical assessment of individuals with elevated cholesterol includes examination of the eyes and tendons, as well as cardiovascular examination including assessment for arterial bruits and signs of peripheral vascular disease. Possible signs of secondary causes, such as hypothyroidism, biliary obstruction, or nephrotic syndrome should also be evaluated.

Laboratory investigations for individuals with hypercholesterolemia include a repeat lipid profile to confirm the diagnosis, as well as blood and urine studies to rule out secondary causes and assess for complications (Table 3). Tests should include HbA1c, fasting glucose, TSH, transaminases, creatinine, creatine kinase, and urinalysis to assess for proteinuria. Unless an individual has known HTG, there is relatively minor impact of fasting vs nonfasting on lipid values obtained (0.2-0.3 mmol/L [8-12 mg/dL]) (113).

Diagnosis. An individualized diagnosis of hypercholesterolemia involves first an assessment of cholesterol levels, generally obtained from a standard lipid profile, as well as an assessment of individual risk, preferably using a validated cardiovascular risk calculator (ie, Framingham risk assessment) (148), SCORE (149), QRISK (150), or American College of Cardiology/American Heart Association (151) to determine the threshold at which cholesterol levels should be clinically addressed.

To diagnose monogenic FH, several clinical scoring systems have been developed. Two of the most widely used are the Simon Broome Register criteria (152) and the Dutch Lipid Network criteria (153, 154), both of which use a combination of lipid values (total cholesterol and/or LDL-C levels); presence of physical stigmata; and personal or family history of premature ASCVD. Pathogenic DNA variants detected in FH-associated genes is the gold standard method of diagnosis, and can be considered in those whose LDL-C levels are >5.0 mmol/L (194 mg/dL).

A practical approach to elevated cholesterol. For most individuals, measuring a nonfasting standard lipid profile is the screening test of choice (Fig. 3). If TGs are elevated >4.5 mmol/L (>400 mg/dL), repeating the level fasting is advised. Before deciding on treatment course, secondary causes should be ruled out.

Treatment with the maximally tolerated dose of a high intensity statin (ie, rosuvastatin or atorvastatin) is recommended as first-line treatment for anyone meeting the following characteristics: (1) LDL-C >5.0 mmol/L (194 mg/dL) (>95th percentile) regardless of ASCVD risk; (2) those at high ASCVD risk based on a validated risk calculator; (3) those with known clinical ASCVD; (4) those with statin-indicated conditions, including diabetes, renal impairment, or abdominal aortic aneurysm; (and 5) LDL-C >3.5 mmol/L (>135 mg/dL) and intermediate ASCVD risk based on a validated risk calculator (43).

For patients whose LDL-C levels do not warrant treatment, or if LDL-C cannot be accurately assessed because of high TG levels, alternative thresholds for clinical action based on apo B or non-HDL-C levels may be used instead, as discussed previously. These alternative measurements may also be used to help guide decisions on treatment intensification.

For those who exceed their threshold or target on maximally tolerated statin, adding additional agents, either ezetimibe in primary prevention or when LDL-C levels that are close to target, or PCSK9 inhibitors in those at higher risk or who require greater LDL-C lowering, should be considered. The general principle of managing cholesterol is that “lower is better,” with no negative effects seen with even the lowest values of LDL-C obtained from clinical trials (155). Therefore, there is no need to deintensify treatment in those who attain very low LDL-C levels (156). An approach to the patient with intolerance to statins is discussed later.

Treatment “targets” vs “thresholds.” Cholesterol recommendations from major guideline organizations differ in several aspects, despite each committee being composed of lipid experts, and evaluating essentially the same evidence. A major difference is the LDL-C level at which treatment intensification is recommended. Some guideline organizations (ie, European Atherosclerosis Society/European Society of Cardiology) (44) have opted for a treatment “target,” which varies based on guideline organization, and some for a treatment “intensification threshold” (ie, Canadian Cardiovascular Society) (43). The difference is subtle but important. A target level implies that maximal benefit is obtained once the target is attained and may lead to providers possibly back-titrating the dose or even deprescribing medication if the attained level is far below the target. However, most clinical trials of cholesterol-lowering agents were performed by selecting patients with LDL-C exceeding a threshold value, and did not aim for a specific target level: some on-treatment patients attained extremely low LDL-C levels and yet continued to show benefit with respect to ASCVD risk reduction (157). Advocates for thresholds suggest that these closely approximate the approach used in the

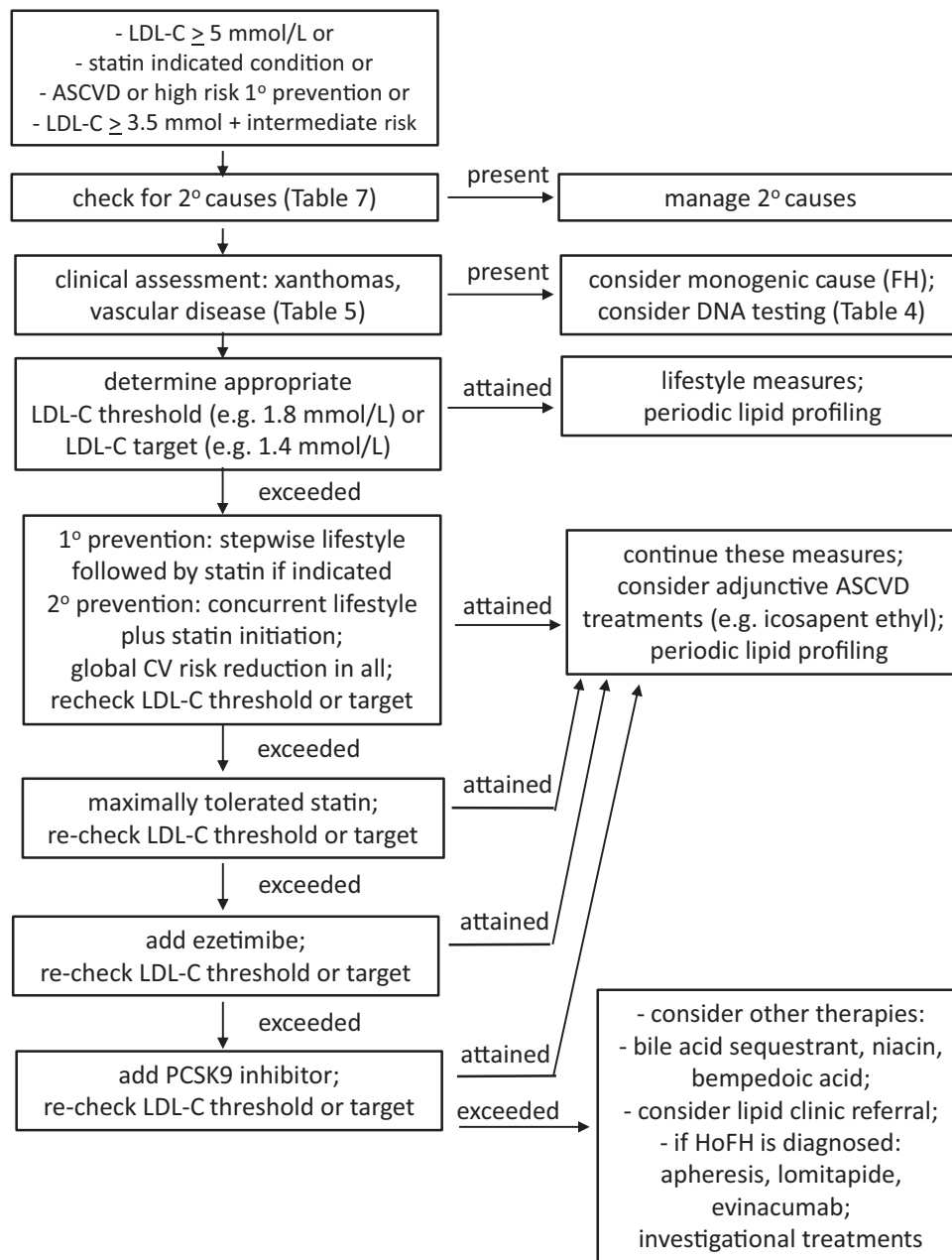

Figure 3. Approach to the patient with high LDL-C.

clinical trials, and are thus consistent with “evidence-based medicine.”

High triglyceride states

Clinical consequences/manifestations. HTG is commonly encountered clinically, with an abnormal TG level on a blood test typically being the only clinical finding. Although there is a lack of worldwide consensus on gradations of HTG, a practical distinction can be made between mild-moderate HTG (ie, TG between 2 and 9.9 mmol/L [175 and 884 mg/dL]), where the clinical consequence is excess ASCVD risk, vs severe HTG (ie, TG

>10 mmol/L [>885 mg/dL]), where there is increased risk of pancreatitis (158).

Physical findings associated with HTG are typically apparent for TG >10 mmol/L (>885 mg/dL). Clinical features of chylomicronemia include failure to thrive in infants, eruptive xanthomas, lipemia retinalis, hepatosplenomegaly, recurrent abdominal pain, nausea and vomiting, and risk of acute pancreatitis (159, 160) (Table 6). Less common clinical features include intestinal bleeding, pallor, anemia, irritability, diarrhea, seizures, and encephalopathy (160). Eruptive xanthomas appear centrally, on the torso, back, buttocks, shoulders, and thighs (161). These are raised clusters of small

yellowish-orange dome-like papules surrounded by erythematous halos (Fig. 2). They may appear suddenly as TG levels abruptly rise, and then recede over weeks to months following a decline in TG levels (161). Lipemia retinalis refers to retinal vessels on fundoscopic examination that appear whitish-pink (Fig. 2). This finding reflects extreme HTG (ie, TG >33 mmol/L [>3000 mg/dL]). Vision is unaffected (159, 162).

Hepatosplenomegaly is caused by lipid accumulation within cells of the reticuloendothelial system. It is also directly related to the degree of TG elevation and is reversible with correction of plasma TG levels (159).

The risk of developing pancreatitis in patients with severe HTG (163, 164) begins to increase with TG >10 mmol/L (>885 mg/dL), rising sharply with TG >20 mmol/L (>1770 mg/dL) (165). Pancreatitis resulting from HTG is sometimes fatal. Complications include chronic pancreatitis, pancreatic insufficiency, pancreatic necrosis, pancreatic abscess, or pancreatic pseudocyst (166).

Pancreatitis in HTG patients is hypothesized to be a consequence of the pathological release of normally exocrine pancreatic lipase into local capillaries, resulting in partial lipolysis of lipoproteins and the generation of free fatty acids (159, 166). These free fatty acids may then prematurely activate trypsinogen and lead to autodigestion of the pancreas (159, 166). Risk of pancreatitis is markedly reduced after lower TG levels are achieved.

HTG and ASCVD risk. The balance of experimental evidence suggests that HTG is also an independent risk factor for the development of ASCVD. Several observational studies have demonstrated a graded association of elevated TG levels with ASCVD risk; however, this association is attenuated following adjustment for confounders that accompany HTG, including obesity, hypertension, insulin resistance, diabetes, depressed HDL-C, increased sdLDL-C particle number, and increases in inflammatory and prothrombotic mediators (65-68, 167, 168).

Mendelian randomization studies have linked genetic elevations in TGs to ASCVD outcomes, supporting TG as an independent risk factor after adjusting for other lipid effects, but again given the huge underlying metabolic pleiotropy associated with elevated TGs, these cannot definitively prove causation in our opinion (65, 69, 70). Studies of individuals with rare large-effect loss-of-function variants in *APOC3* who naturally have low TG levels and reduced rates of ASCVD compared with the general population, further support a causal link, but again these individuals concurrently have reduced LDL-C and increased HDL-C compared with those who without such variants, suggesting that although apo C-III may be a valid therapeutic

target, its potential benefits are not solely mediated via an effect on TG levels (169, 170).

Furthermore, evidence for the benefit of lowering TG pharmacologically to improve ASCVD outcomes is currently lacking. Most agents that lower TGs also affect other components of the lipid profile. A meta-analysis (171) of 49 lipid trials was conducted and a multivariable meta-regression determined a relative risk reduction of 0.84 (95% CI, 0.75-0.94) per 1 mmol/L reduction in TG. The Reduction of Cardiovascular Events With Icosapent Ethyl – Intervention Trial, a randomized trial of icosapent ethyl in high ASCVD-risk individuals with TGs 1.5 to 5.6 mmol/L also showed improved ASCVD outcomes (172), although the benefit was unrelated to the degree of TG lowering (173).

Secondary causes. Most cases of adult-onset HTG result from secondary causes. These are usually conditions that increase TG production and/or impair clearance and include obesity, metabolic syndrome, diet with high positive energy-intake balance, diet rich in fat or simple sugars (ie, high glycemic index diet), alcohol consumption, type 2 diabetes, renal disease (uremia or glomerulonephritis), pregnancy (mainly the third trimester), paraproteinemia, systemic lupus erythematosus, and some medications, including corticosteroids, oral estrogen, tamoxifen, thiazides, noncardioselective beta-blockers, bile acid sequestrants, cyclophosphamide, antiretroviral drugs, and second-generation antipsychotic agents (46, 73, 174-178) (Table 7).

Monogenic causes

Familial chylomicronemia syndrome. FCS is an ultrarare condition with an estimated prevalence of 1 in 300 000 in the general population. FCS typically presents in infancy, childhood, or adolescence (12, 26, 179, 180). More than 80% of cases result from biallelic rare loss-of-function variants in the *LPL* gene, that encodes for LPL, the enzyme that removes TG from circulation (181) (Fig. 1). Rare biallelic loss-of-function variants in 4 genes encoding proteins that support the function of LPL—namely *APOC2*, *APOA5*, *LMF1*, or *GPIHBP1*—account for 20% of FCS cases (181).

Management of FCS can be challenging, and often requires strict adherence to a very low-fat diet (<15%-25% of calories from fat or <20-50 g/day) (182). Medium-chain triglycerides are sometimes supplemented in the diet replacing other fats to meet nutrient requirements.

Most standard pharmacologic agents for elevated TG, such as fibrates, niacin, and omega 3 fatty acids, are ineffective in FCS patients, although they are still often tried. For FCS patients who suffer from recurrent episodes of pancreatitis, other investigational options include drugs

targeting apo CIII, such as volanesorsen, which was approved in Europe for the treatment of patients with FCS and recurrent pancreatitis (183-185). Volanesorsen was denied approval by the US Food and Drug Administration (FDA) because of its tendency to cause thrombocytopenia (186). Therapies targeting ANGPTL3 are in late-stage development and may offer a promising new therapy for individuals with FCS (187).

Dysbetalipoproteinemia. Dysbetalipoproteinemia, former type 3 or remnant disease, affects ~ 1 in 10 000 individuals and does not typically manifest until adulthood in men and in postmenopausal women (188). The biochemical definition includes concomitant—classically equimolar—elevations of TC, typically from 6.5 to 11.6 mmol/L (250-1000 mg/dL) and TG, typically from 2.3 to 10 mmol/L (100-885 mg/dL). The pathognomonic feature derived from ultracentrifugation of plasma is a molar ratio of VLDL-C to total TG >0.75, although this is methodology is essentially unavailable today (172). The main lipoprotein disturbance is accumulation of IDL and chylomicron remnants resulting from impaired clearance (189, 190). LDL-C, when directly measured, tends to be low because of impaired processing of IDL to LDL.

Dysbetalipoproteinemia has unique physical manifestations, including tuberous or tuberoeruptive xanthomas, which generally appear on extensor surfaces such as the elbows and knees and less commonly on the buttocks (Fig. 2) (190). Palmar crease xanthomas are also unique for dysbetalipoproteinemia (Fig. 2) (190). Patients with dysbetalipoproteinemia are at increased risk of premature coronary artery disease and peripheral arterial disease.

Most individuals with dysbetalipoproteinemia are homozygous for the binding-impaired apo E2 isoform encoded by the *APOE* E2 allele (190). However, this genotype on its own is insufficient to cause the condition; nongenetic secondary factors such as obesity, diabetes, and hormone use are often present. As mentioned, we have observed that about one-half of individuals with dysbetalipoproteinemia also have high polygenic scores for HTG (Hegele, unpublished observations). Finally, ~10% of patients with dysbetalipoproteinemia have a rare dominant negative *APOE* variant rather than E2/E2 homozygosity (191).

Because the diagnosis may be challenging in the absence of genotyping and/or ultracentrifugation, patients simply appear to have combined hyperlipidemia, and their management follows treatment of the main lipid disturbance, usually HTG, addressing secondary factors, diet and lifestyle modification, and appropriate drug treatment (Fig. 4).

Polygenic basis of elevated TG

Most patients with either mild-to-moderate or severe HTG have strong polygenic predisposition, with polygenic scores derived from SNP loci associated with elevated plasma TG, as described previously for LDL-C (33, 46). There is an impulse among clinicians to ascribe a monogenic cause (ie, FCS) to any patient with severe HTG, but FCS patients represent only ~1% of all cases of patients with TG >10 mmol/L (>885 mg/dL) (181). The metabolic phenotype in patients with polygenic HTG tends to be less severe than those with FCS (182). Individuals with polygenic HTG tend to present later in life, usually as adults and often not until middle age, and have lower mean TG levels, less severe physical manifestations, and fewer complications.

Investigations. Physical assessment of individuals with HTG should include a careful examination of torso, back, buttocks, shoulders, extremities, and palms to assess for physical stigmata of HTG as well as assessment for hepatomegaly, and cardiovascular and peripheral vascular disease.

Laboratory investigation of individuals with HTG includes a repeat fasting lipid profile, as well as blood and urine studies to rule out secondary causes and assess for complications. Plasma from individuals with chylomicronemia will appear turbid and milky, described as “lipemic.” If allowed to settle overnight, it develops a cream-like supernatant above a clear infranatant. Other laboratory tests should include glycated hemoglobin, fasting glucose, thyrotropin, transaminases, creatinine, and urinalysis to screen for proteinuria. Evaluation for systemic lupus erythematosus or Cushing syndrome could be considered if clinically indicated.

Diagnosis. HTG is usually a biochemical diagnosis, based on fasting plasma TG concentration above a certain cut point (Table 3). Many laboratories report the ULN of TG as 1.7 mmol/L (150 mg/dL), whereas the 95th percentile for plasma TG is ~3.0 to 3.4 mmol/L (265-300 mg/dL) for North American adults. Severe HTG is sometimes diagnosed when fasting plasma TG concentration is >10 mmol/L (>885 mg/dL) or >11.1 mmol/L (>1000 mg/dL).

Approach to the patient with hypertriglyceridemia-associated pancreatitis

HTG is an uncommon but important cause of pancreatitis, thought to underlie up to 10% to 14% of pancreatitis cases (192). Cohort studies suggest that HTG-associated pancreatitis may have greater morbidity and mortality compared with pancreatitis from other causes (163, 193, 194). HTG-associated pancreatitis should generally

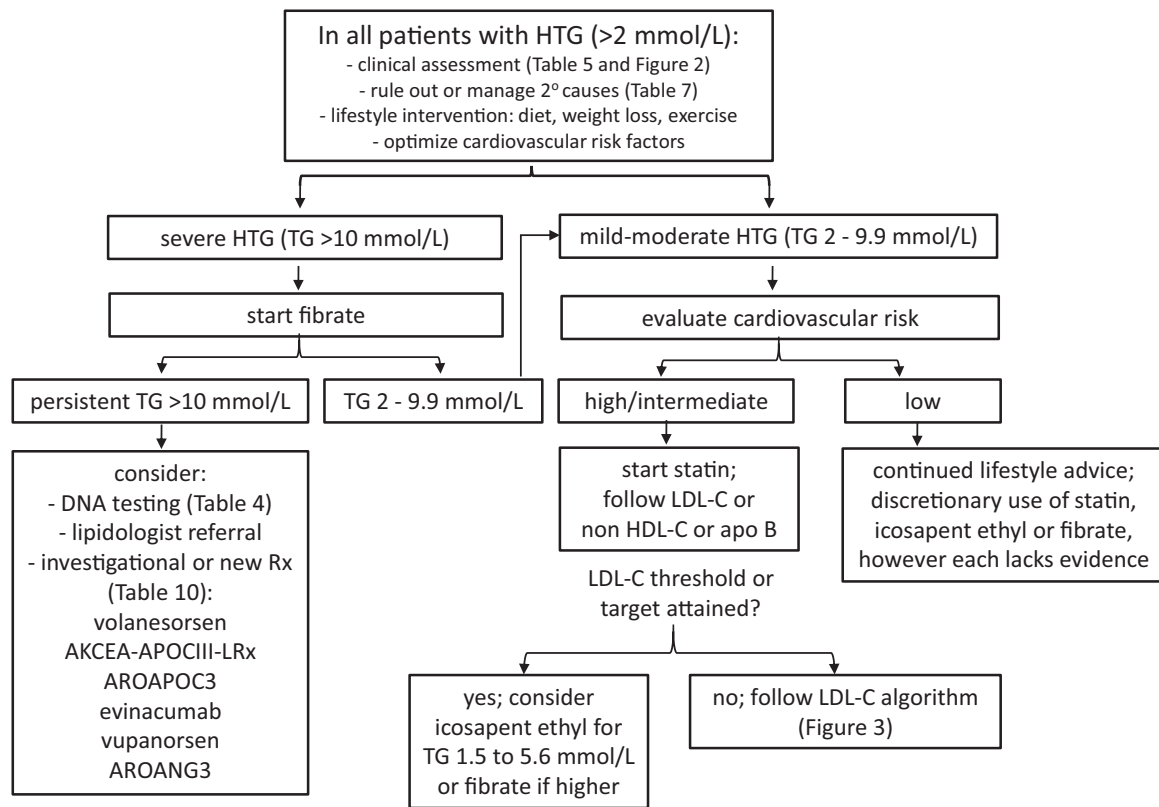

Figure 4. Approach to the patient with high TG.

be managed supportively and conservatively, by withholding oral intake and administration of IV fluids. Use of insulin infusions, heparin, or plasmapheresis have also been proposed as modes of treatment designed to more rapidly lower TG (195-197). There is a lack of definitive evidence to support any of these approaches as superior to conservative management (198). Although the degree of TG elevation is correlated with pancreatitis severity, there is no evidence to suggest that the course of pancreatitis will be altered if TG levels are lowered more rapidly once an episode has been triggered. Furthermore, TG levels will rapidly fall following cessation of oral intake, with a half-life of ~30 hours (199). Uncontrolled studies have failed to show benefit for plasmapheresis in terms of morbidity, mortality, or pancreatitis severity (198). Similarly, evidence of benefit in terms of outcomes for insulin infusions to treat HTG levels in those who without concurrent hyperglycemia is lacking (200); this treatment would increase the risk of hypoglycemia (201). For most patients, we recommend a conservative approach that consists of withholding oral intake, supportive IV fluids, and appropriate pain management.

A practical approach to hypertriglyceridemia

In any adult with newly recognized HTG, there are frequently contributing secondary causes (Table 7).

Addressing these secondary causes often goes a long way toward correcting the HTG in many cases, and should be the first line of management (Fig. 4). In the patient with severe HTG, and a history of HTG-associated pancreatitis, or an individual whose fasting TG levels remain > 10 mmol/L (>885 mg/dL) on repeat fasting lipid profiling, without an obvious and treatable secondary cause (eg, alcohol binge, decompensated diabetes) likely warrants treatment to protect against pancreatitis. The first-line drug treatment in these cases should be a fibrate.

For all others with mild to moderate HTG, the primary concern is the potential for excess ASCVD risk. ASCVD risk factors should be managed concurrently, such as hypertension, obesity, sedentary lifestyle, smoking, and diabetes. Medications with proven cardiovascular benefit, such as statins, ezetimibe, and icosapent ethyl, are preferred if pharmacological treatment is required, although paradoxically these are less effective at lowering TG levels than fibrates, for which evidence of ASCVD benefit is more tenuous. Because LDL-C may be impossible to determine in a statin-treated patient with persistently elevated TG, non-HDL-C, and/or apo B are alternative tests for treatment thresholds and for monitoring the effects of therapy.

For those with a history of HTG-associated pancreatitis, but who currently have only mild-to-moderate HTG, a case can still be made for treatment with a fibrate to reduce the future risk of pancreatitis. Mild-to-moderate TG elevation

is a predictor of future risk of severe HTG and of development of pancreatitis (202).

Finally, for those at low cardiovascular risk, with TG levels below pancreatitis threshold, management of secondary contributors is the recommended course of action.

Hypertriglyceridemia in pregnancy

Pregnancy can present a challenge in women predisposed to HTG because the rise in estrogen, particularly in the third trimester, can raise plasma TG levels (177). Until recently, it was advised that women taking statins before pregnancy should stop these when they are trying to conceive or as soon as they are aware of the pregnancy; however, in July 2021, the US FDA removed this prohibition for women who are at very high ASCVD risk (203). Omega 3 fatty acids are considered safe to continue during pregnancy. Fibrates have not been specifically studied in pregnancy but are not known to be teratogenic in humans. If it is possible for women treated with a fibrate or statin before pregnancy to safely stop these treatments, they should be held before conception. For women who have a history of pancreatitis with TG > 10 mmol/L (>885 mg/dL), reintroduction of a fibrate may be recommended, especially beyond the first trimester.

Diet is a key component of managing TG levels throughout pregnancy, and all women should be advised on following a low glycemic index diet. Dietician consultation would be suggested for those with severe TG elevations. For women with resistant HTG, for instance with TG >20 mmol/L (>1770 mg/dL), admission to the hospital, supportive fluid replacement, and temporary withholding of oral diet may be advisable (204). In extreme cases of resistant HTG, plasmapheresis may be considered as a last resort, but can be discontinued after delivery (205).

Approach to the patient with abnormal HDL-C

Although levels of HDL-C were once regarded as reliable predictors of ASCVD risk, current evidence suggests that there is little to be gained in therapeutically targeting them. Individuals with either extremely high or low HDL-C levels show increased mortality compared with those with average HDL-C levels (206-208). Biochemical and molecular studies indicate that HDL is a vast network of complex particles with widely differing composition and functional attributes (209) rather than a concrete species with limited complexity, such as apo B-containing lipoproteins (210). Furthermore, it seems that HDL's functional attributes, such as its ability to transact cellular cholesterol efflux, are more physiologically relevant than the cholesterol in the core of the particles (211). HDL is prone to chemical modifications that alter its effectiveness in preventing ASCVD

(212). The lack of reliable and accessible clinical assays of HDL function is a major impediment to moving this field forward (213).

Nonetheless, HDL-C is routinely reported with the patient's lipid profile, although its main practical utility is within equations to calculate values for LDL-C and non-HDL-C and the ratio of total to HDL cholesterol. What is the appropriate approach when HDL-C on a routine lipid panel is flagged as being outside the "normal" range?

A low HDL-C is most commonly seen in patients with elevated TG levels. In this scenario, diagnosis and management would devolve to the algorithm for elevated TG (Fig. 4) and ruling out any secondary factors. Because genetic determinants of the joint elevated TG and depressed HDL-C phenotype are typically polygenic, there is no reason for genetic evaluation in these patients, unless a monogenic cause of severe HTG such as FCS is seriously being considered. Treatment would be centered on reducing levels of atherogenic lipoproteins, including apo B-containing TG-rich particles and remnants. Lifestyle measures such as improved diet and especially exercise appear to have clear benefits on HDL function (214), although, as mentioned, this cannot be assessed by any current clinical assays.

In the second scenario, HDL-C is low in isolation, without concomitant deviation in TG levels or indeed any other lipoproteins (215). This situation can arise from the same secondary factors that raise TG levels, so these should be ruled out. In cohort studies of >900 individuals with isolated low HDL-C, we found that overwhelmingly the genetic basis is polygenic (216), meaning that the phenotype is usually determined by the accumulated contribution of many common SNP variants that each act incrementally to lower HDL-C. A smaller proportion of such patients instead has a single copy of a pathogenic variant in a gene for which 2 copies cause severe monogenic HDL-C deficiency syndromes, as shown in Tables 4 and 5 (216). At present, there is no evidence that knowing the precise genetic basis of low HDL-C affects management. Thus, genetic testing is not recommended, unless the isolated HDL-C deficiency is so extreme that a monogenic condition such as Tangier disease (217), apo A-I deficiency (218), or LCAT deficiency (219) is suspected. Rare monogenic HDL-C deficiency states may require specialized attention because of possible systemic involvement. Otherwise, management of a patient with isolated low HDL-C includes prudent lifestyle advice and pharmacotherapy that focuses on optimizing management of atherogenic apo B-containing lipoproteins, using statins as the first step.

Finally, for patients with extremely elevated HDL-C, we no longer assume that this metabolic state is cardioprotective. In addition to epidemiologic evidence that patients with markedly elevated HDL-C are not

protected from ASCVD, families with monogenic disorders of high HDL-C, such as those with SR-B1 deficiency (220), CETP deficiency (221), and HL deficiency (222), also have increased ASCVD risk. Very high HDL-C levels are misleading because the HDL particles are likely poorly functional or even pro-atherogenic. Furthermore, many patients have markedly elevated HDL-C on a polygenic basis (216). At present, there is no evidence for any clinical actionability in these cases using genetic analysis. Secondary causes are most frequently oral estrogen replacement therapy in postmenopausal females, and also excessive alcohol consumption, which in some patients results only in increased HDL-C without any collateral effect on the TG metabolic axis. Our approach with such patients is to disregard the elevated HDL-C and focus on the atherogenic lipoprotein species, adhering primarily to the algorithms in Figs. 3 and 4.

Combined hyperlipidemia

CHL is a complex phenotype that is often associated with early ASCVD (223). CHL affects ~ 1 in 50 adults in most Westernized societies (224). CHL has been considered to be synonymous with Fredrickson type 2B, characterized biochemically by concurrently elevated LDL and VLDL, resulting in increased TC, non-HDL-C and LDL-C, and TG, often with depressed HDL-C (225). Elevated apo B is a defining feature of CHL (226) because it is the main protein component of non-HDL, LDL, and VLDL. The most direct way to distinguish CHL from FH, in which apo B is also elevated, is by the concurrent TG elevation in CHL. Terms such as “combined dyslipidemia” or “mixed dyslipidemia” are also sometimes used to describe CHL. CHL also largely overlaps with the so-called “atherogenic dyslipidemia complex,” which is associated with obesity, insulin resistance, and type 2 diabetes (227); this association reinforces the important role of secondary factors underlying this phenotype.

We suggest that the term “familial combined hyperlipidemia” is misleading because the adjective “familial” gives the impression that this lipid trait is monogenic, like FH (228). But genetic studies have never identified any single gene determinants of CHL. Using targeted next-generation DNA sequencing together with polygenic analysis, we recently showed that CHL is essentially a polygenic trait whose genetic architecture resembles that of polygenic HTG (31). We found no evidence of a monogenic component in CHL patients, with no enrichment of rare variants in FH-causing or lipolysis-associated genes (31).

Thus, although CHL has a genetic basis, it is a non-Mendelian trait. Genetic susceptibility to CHL results from multiple common variants that accumulate within

the genomes of affected family members. These multiple underlying common genetic variants cluster in families, so CHL also clusters in families but is not inherited across generations following Mendelian rules. Furthermore, the multiple genetic factors segregate independently on different chromosomes, so their precise mix varies between family members, as does the resulting phenotype (228).

Management of CHL patients begins with ruling out secondary factors, expanding the lipid profile with apo B and possible Lp(a) determination, and assessment of ASCVD risk. Genetic analysis is not generally helpful because the CHL is polygenic and there is no evidence at present that this information is clinically actionable. Treatment includes correcting secondary factors, lifestyle modification with weight loss, improved diet, and alcohol restriction, and medication, guided by the algorithms for the individual lipid perturbations. Typically, statin and/or ezetimibe are used first, and TG-lowering therapies such as icosapent ethyl or fibrates can be added if significant residual HTG remains.

Elevated Lp(a)

Lp(a) structure, function, and genetics. Lp(a) is a distinct lipoprotein that shares structural similarity to LDL, with a single apo B-100 molecule on its surface (229). Unlike LDL, however, Lp(a) has a unique polymorphic apo(a) glycoprotein tail covalently linked to the apo B-100 via disulfide bridging (229). The apo(a) tail contains 5 “kringles,” or cysteine-rich domains, with the fourth being structurally similar to plasminogen, an antithrombotic plasma protein (230). Although Lp(a) has similar cholesterol content to LDL, it is structurally, metabolically, and pathogenically distinct. While there are no clearly defined genetic syndromes associated with Lp(a), levels are largely genetically determined, with size polymorphisms in coding regions of the *LPA* locus encoding different sizes of apo(a) isoforms, which account for > 90% of the variation in serum Lp(a) concentrations between individuals (231). In 2018, the Centers for Disease Control and Prevention introduced a new diagnostic code for elevated Lp(a), namely International Classification of Diseases-10 E78.41.

Role of Lp(a) in ASCVD. There is a strong association between Lp(a) levels and risk for ASCVD. Because apo(a) shares structural similarity with plasminogen, it is hypothesized that the apo(a) itself plays a direct role in atherogenesis and/or thrombosis (Table 6). Proposed mechanisms for the prothrombotic effect of Lp(a) include competitive inhibition of plasminogen leading to a decrease in fibrinolysis (231, 232). Lp(a) particles also interact with endothelial macrophages, generating foam

cells and atherosclerotic plaques, as well as potentially enhancing oxidation of LDL (233). Lp(a) is found within human atheroma and in a greater relative amount in plaques from individuals with unstable compared with stable heart disease (234). The molar concentration of Lp(a) determines ASCVD risk, rather than Lp(a) cholesterol content or particle size (235).

Investigations and measurement. There is no consensus regarding screening individuals for Lp(a) levels. Some guideline committees, such as the European Atherosclerosis Society/European Society of Cardiology and Canadian Cardiovascular Society, suggest measuring Lp(a) once as an adult for risk stratification (43, 44). Other societies, such as the National Lipid Association, suggest screening only in high-risk situations, such as in individuals with a personal or family history of premature ASCVD, or those with known FH (236). At high concentrations, Lp(a) can interfere with LDL determination as a substantial portion of measured LDL-C may be contained within Lp(a) particles; therefore, measurement of Lp(a) may also be warranted in anyone who presents with LDL-C levels >5.0 mmol/L (>194 mg/dL) or reduced responsiveness to statins.

Because circulating Lp(a) is thought to remain relatively stable throughout life, once a baseline level is obtained, further monitoring is not required (237). Mass measurements of Lp(a) are less useful for predicting ASCVD risk; therefore, assays that measure molar concentrations are preferred (235). A high level of Lp(a) is considered to be ≥ 125 nmol/L (≥ 50 mg/dL) (238).

Management. Pharmacologic treatments targeting Lp(a) are currently in development, with an antisense oligonucleotide against Lp(a) demonstrating up to an 80% lowering (239). Ongoing outcome studies will establish if there is a role for this agent to treat elevated Lp(a) in ASCVD prevention. Until this is clarified, management of other ASCVD risk factors should be the mainstay of treatment for individuals with elevated Lp(a) (43). More aggressive LDL-C lowering than would otherwise be recommended based on cardiovascular risk assessment may be warranted in those with elevated Lp(a).

Of currently approved lipid agents, statins can elevate Lp(a) levels, but are nonetheless considered first-line treatment in patients with high Lp(a) because of their general benefit with respect to elevated ASCVD risk (240). Ezetimibe has a neutral effect on Lp(a), whereas niacin lowers Lp(a). In a meta-analysis that included 6566 individuals, PCSK9 inhibitors lowered Lp(a) by 26%, although Lp(a) lowering is not currently an approved use for these agents (241).

Special populations

Lipodystrophy. Lipodystrophies are a heterogeneous collection of inherited and acquired disorders characterized by abnormal distribution of adipose tissue (Tables 4 and 5), with regional lack of subcutaneous adipose tissue and pathological accumulation of fat within other body regions. They are underrecognized clinically but often present with features of severe insulin resistance and hypertriglyceridemia, often at a young age. These conditions are an important consideration in individuals who present with this phenotype. Initial management follows the same principles as those without lipodystrophy, although thiazolidinediones may be considered preferentially after metformin for management of insulin resistance and hypertriglyceridemia. In extreme cases of generalized lipodystrophy, treatment with metreleptin, a synthetic leptin analog, can be a consideration; however, high costs and lack of trial data supporting its long-term benefit and safety limit its viability. Also, emerging agents for severe hypertriglyceridemia discussed next are worth considering.

Type 1 diabetes. Individuals with type 1 diabetes are at increased risk for ASCVD, which is partially mediated by dyslipidemia. Poor or suboptimal glycemic control (HbA1c $>7.5\%$) in individuals with type 1 diabetes is associated with elevations in atherogenic lipoproteins including TG, LDL-C, and non-HDL-C, that are likely from increased VLDL production from relative insulin deficiency (242). Conversely, individuals with well-controlled type 1 diabetes often appear to have quantitatively favorable lipid profiles, with normal to low triglycerides and LDL-C (242). These quantitative improvements are hypothesized to be related to peripheral hyperinsulinemia that results from the subcutaneous delivery of insulin (242). However, even individuals with type 1 diabetes who appear to have quantitatively normal lipid profiles may have qualitative lipoprotein abnormalities that can potentially predispose to ASCVD, such as increased levels of sdLDL, higher rates of LDL oxidation, and dysfunctional HDL-mediated reverse cholesterol transport (242). An apparently normal lipid profile in these patients may therefore be falsely reassuring.

Adolescents with metabolic syndrome. With the increasing prevalence of obesity among adolescents, metabolic syndrome with associated dyslipidemia is becoming more common in this population. Lifestyle modification should be emphasized in this population, including adoption of a calorie-restricted diet with reduced intake of simple carbohydrates and saturated fats, adequate physical activity, and weight loss.

If required, adequate management of hyperglycemia with metformin with or without insulin may lead to improvement in hypertriglyceridemia. High-dose omega 3 fatty acids may be the first-line pharmaceutical agent of choice if additional therapy is required to manage hypertriglyceridemia in this age group. Fibrates and/or statins may also be considered in select severe cases, usually under the guidance of a lipid specialist.

Management of patients with dyslipidemia

General principles for dyslipidemia management. Clinical practice guidelines recommend LDL-C as the primary target of therapy to reduce ASCVD risk (42–44) (Figs. 3–5). Treatment thresholds or targets for LDL-C are recommended for patients who are stratified into risk categories using risk algorithms such as the Framingham Risk Score. For instance, North American lipid guidelines advise that high-risk subjects with existing ASCVD or a statin-indicated condition such as diabetes, renal insufficiency, or FH should have lipid-lowering therapy intensified if LDL-C is >1.8 mmol/L (>70 mg/dL), with no lower limit for treatment (42, 43). In contrast, European guidelines recommend a target LDL-C level <1.4 mmol/L (<54 mg/dL) for these patients (44). In all cases, intervention to reduce LDL-C includes lifestyle management and if necessary, pharmacologic therapies. Certain monogenic disorders, specifically FH, are associated with dramatically increased ASCVD risk, placing these individuals into the highest risk strata, and emphasizing the importance of making this diagnosis.

Lifestyle interventions

In general, the type and severity of the dyslipidemia dictates the intensity of the intervention. For less severe dyslipidemia, restricting saturated fat while increasing aerobic activity may largely correct the lipid profile. Because only a minority—15% to 20%—of serum cholesterol is derived from dietary sources, dietary management is often insufficient on its own to substantially lower plasma cholesterol. However, diet can be an important adjunct to pharmacological management of elevated LDL-C, and helps reduce medication dosages.

In contrast, dietary management is relatively more effective in many patients with HTG; diet and weight loss are sometimes sufficient to manage levels in individuals with mild-to-moderate HTG.

General dietary interventions for dyslipidemia include: (1) overall reduction in intake and reduced portion sizes; (2) redistribution of relative quantities of sources of

calories (eg, replacing high glycemic index foods with complex carbohydrates) and replacing trans and saturated fats with mono- and polyunsaturated fats (243) (eg, choosing lean meat such as fish or poultry over fattier red meats); (3) addition of specific foods that may have beneficial effects on the lipid profile (eg, soluble fiber and plant sterols can reduce LDL-C by 6%–14%) (244, 245); and (4) elimination of specific components that perturb the lipid profile (eg, eliminate alcohol in some patients with elevated TG) (42–44).

For severe hypercholesterolemia and HTG, as encountered in some monogenic conditions, more severe dietary restrictions are advised. A specialized dietician is helpful in these circumstances. For individuals with severe HTG, a low-fat diet ($<30\%$ of total daily caloric intake) may be recommended, with potentially more severe fat restriction ($<15\%$ of total daily caloric intake) in those with TG persistently >10 mmol/L (>885 mg/dL) (182).

Recommendations of intensity of regular exercise depend on the health and fitness of the patient; adults and children with no restrictions should engage in activities equivalent to a daily total of 30 to 60 minutes of moderately intense physical activity 3 to 5 times per week. Exercise not only contributes to neutral or negative caloric balance, thus blunting weight gain and combatting obesity, but it can also increase insulin sensitivity, which in turn improves lipolysis and promotes catabolism of TG-rich lipoproteins.

Finally, given the lack of effective targeted pharmacologic therapies in individuals with low HDL-C, lifestyle modifications targeted toward minimizing ASCVD risk are the mainstay of management in these patients. These include regular exercise, attaining ideal body weight, smoking cessation, and maintaining a healthy diet, all of which also raises HDL-C. Indeed, management of other ASCVD risk factors is important for all individuals with dyslipidemia, including smoking cessation and control of elevated blood pressure and blood glucose.

Pharmacological therapy

The priority of drug therapy is to reduce LDL-C to comply with guideline recommended treatment thresholds or targets. The patient's level of risk guides the timing of treatment initiation and the intensity of the treatment. In general, drug therapy may be started together with lifestyle intervention in high-risk patients. The response to drug therapy and possible adverse effects should be checked with a repeat lipid profile in about 6 to 8 weeks and recommendations on dose adjustment made at that time. Once drug therapy has been decided upon for

ASCVD risk reduction, an LDL-lowering drug is almost always the first step.

LDL-C lowering agents

Statins. Statins are oral agents that inhibit HMGCR, thus depleting intracellular cholesterol and upregulating the LDL receptor, which in turn increases LDL particle catabolism and lowers plasma LDL-C levels (246). Statins also have a minor effect on reducing secretion of apo B-containing lipoproteins (247). This resulting decrease in circulating LDL particles reduces the proportion of plasma cholesterol residing within LDL by 30% to 50% depending on agent, dose, pharmacogenetic factors, and compliance. This in turn reduces exposure of the arterial wall to the deleterious effects of LDL (248). The definitive meta-analysis of 27 randomized statin trials found that for each 1 mmol/L (38.7 mg/dL) of LDL-C reduction, there was a significant 9% reduction in all-cause mortality and a 21% reduction in major ASCVD events (249). Statins are very widely used (250), are generally well tolerated, and only very rarely cause severe myopathy or hepatic toxicity (251). About 10% of patients report annoying myalgia symptoms, which can reduce compliance but are reversible and not threatening to health (251–254). With high doses of statins, there is a small increased risk of developing diabetes among predisposed individuals who would likely have developed this in any event (251). Available statins include lovastatin, simvastatin, pravastatin, fluvastatin, atorvastatin, rosuvastatin and pitavastatin (Table 8).

Approach to the patient with statin intolerance

Statin intolerance can be a significant barrier to optimal lipid management (Fig. 5). Adverse effects attributed to statins that can lead to discontinuation are numerous, and include those that affect the musculoskeletal, gastrointestinal, neurocognitive, and nervous systems. The most prevalent of these are the statin-associated muscle symptoms (SAMS) (255, 256). These can take the form of muscle pain, aches, stiffness, tenderness, or cramps and usually present without elevations in CK. There is no universally accepted definition for SAMS, although the National Lipid Association has proposed a clinical scoring system based on symptomatology and temporal associations (257). There is significant heterogeneity in SAMS presentation; most common is involvement of the proximal large muscle groups including the thighs, buttocks, calves, and back muscles, typically in a symmetrical pattern. These symptoms usually occur within the first 4 to 6 weeks after statin initiation but may occur after several years of treatment. SAMS with CK elevations $>10\times$ ULN occurs in

1 in 10 000 and rhabdomyolysis in 1 in 100 000 individuals per year of statin treatment (255, 256).

Some of the muscle symptoms reported with statins may be due to a placebo effect, suggested by the findings of N-of-1 statin trials and by the lack of a signal for SAMS in blinded trials (123, 258, 259). Furthermore, most patients who are intolerant to 1 statin can successfully be switched to another statin (253).

Management of SAMS (Fig. 5) (255) starts with a conversation with the individual patient about the indication for statin treatment and the expected benefit of continued therapy. Preference for continued statin therapy over alternatives should be stressed. For those patients with SAMS and elevation in CK $<5\times$ ULN, options include continuation of the statin without discontinuation if symptoms are tolerable. If discontinuation is favored, symptoms should be reassessed after 2 to 4 weeks. If no improvement is noted, symptoms are likely unrelated to the statin and statin can be reinitiated. If symptoms improve, options include cautiously rechallenging with the original offending statin or switching to an alternative statin, at the usual starting doses. If symptoms recur with this challenge or CK was $>5\times$ ULN at initial assessment, options include rechallenge of the original statin at a lower dose, trial of a lower intensity statin (ie, fluvastatin, pravastatin), or trial of a high-intensity statin with longer half-life (ie, rosuvastatin, atorvastatin, pitavastatin) with modified dosing regimen (ie, alternate days, once, twice, or 3 times weekly). Of the available statins, simvastatin may be most associated with SAMS, and fluvastatin the least (252). Muscle symptoms seem to be dose dependent but unrelated to the degree of LDL lowering (260).

Cholesterol absorption inhibition

Ezetimibe, the only available cholesterol absorption inhibitor, lowers LDL-C by inhibiting Niemann-Pick C1-like protein 1 in the upper small intestine (261). Ezetimibe is available at a single dose of 10 mg daily and specifically lowers LDL-C levels by 18% to 25%; the ezetimibe-statin combination can lower LDL-C by up to 70%. Ezetimibe is well tolerated with minimal side effects. The cardiovascular benefit of ezetimibe was demonstrated in the Improved Reduction of Outcomes: Vytorin Efficacy International Trial study (262), which enrolled 18 144 patients with acute coronary syndrome. The study showed that reducing LDL-C from 1.8. to 1.4 mmol/L by adding ezetimibe to statin therapy over 7 years was associated with a further ~7% reduction in major adverse cardiovascular events, which was even more pronounced among patients with diabetes. Other randomized trials showed cardiovascular benefit of ezetimibe when used as monotherapy in patients >75 years (263) and in combination with a statin in patients

Table 8. Currently available lipid-lowering therapies

Class	Agent	Dose	Mechanism of action	Main indication	Comments
Statin	Lovastatin	20-80 mg/d	Inhibits HMG CoA reductase	ASCVD prevention	↓LDL-C by 25%-40%
	Simvastatin	20-80 mg/d	Inhibits HMG CoA reductase	ASCVD prevention	↓LDL-C by 30%-45%
	Pravastatin	20-80 mg/d	Inhibits HMG CoA reductase	ASCVD prevention	↓LDL-C by 25%-40%
	Fluvastatin	20-80 mg/d	Inhibits HMG CoA reductase	ASCVD prevention	↓LDL-C by 22%-40%
	Atorvastatin	10-80 mg/d	Inhibits HMG CoA reductase	ASCVD prevention	↓LDL-C by 35%-50%
	Rosuvastatin	5-40 mg/d	Inhibits HMG CoA reductase	ASCVD prevention	↓LDL-C by 35%-55%
CAI	Pitavastatin	1-4 mg/d	Inhibits HMG CoA reductase	LDL-C reduction	↓LDL-C by 22%-40%
	Ezetimibe	10 mg/d	Blocks NPC1L1	ASCVD prevention	↓LDL-C by 18%-25% as monotherapy or added to statin
BAS	Cholestyramine	8-24 g/d	Depletes liver cholesterol	ASCVD prevention	↓LDL-C by 8%-20% as monotherapy or added to statin
	Colesevelam	0.625-3.75 g/d	Depletes liver cholesterol	LDL-C reduction	↓LDL-C by 8%-20% as monotherapy or added to statin
PCSK9 MAb	Evolocumab	140 mg every 2 weeks or 420 mg q 4 weeks	Prevents LDLR degradation	ASCVD prevention	↓LDL-C by 50%-70% as monotherapy or added to statin
	Alirocumab	75 or 150 mg Every 2 weeks	Prevents LDLR degradation	ASCVD prevention	↓LDL-C by 50%-70% as monotherapy or added to statin
PCSK9 siRNA	Inclisiran	300 mg SC every 3-6 mo	Prevents LDLR degradation	LDL-C reduction	↓LDL-C by 45%-55%
	Gemfibrozil	600 mg BID	PPAR-alpha agonist	TG reduction	↓TG by 20%-40%
Fibrates	Fenofibrate	145, 160, 200 mg/d	PPAR-alpha agonist	TG reduction	↓TG by 20%-40%
	Bezafibrate	400 mg/d	PPAR-alpha agonist	TG reduction	↓TG by 20%-40%
	Pemafibrate	0.1-0.2 mg/d	PPAR-alpha agonist	TG reduction	↓TG by 20%-40%
EPA	Icosapent ethyl	2 g BID	Highly pleiotropic	ASCVD prevention	↓TG by 15%-20%
	Epanova	2 g BID	Unknown	TG reduction	↓TG by 15%-20%
Other	Lomitapide	10-80 mg/d	MTP inhibitor	LDL-C reduction	Mixture of n-3 FAs ↓LDL-C by 30%-50% and ↑TG by 15%-40%
	Nicotinic acid	2-3 g/d	Unclear	↓LDL-C and TG	↓LDL-C by 15%-20% and TG by 20%-30%; no CV benefit; declining use
	Bempedoic acid	180 mg/d	Inhibits ACLY	LDL-C reduction	↓LDL-C by 15%-20% as monotherapy or added to statin
	BA + ezetimibe	180 mg + 10 mg/d	Inhibits ACLY + blocks NPC1L1	LDL-C reduction	↓LDL-C by 50%

Abbreviations: ACLY, ATP-citrate lyase; ASCVD, atherosclerotic cardiovascular disease; ASO, antisense oligonucleotide; BA, bempedoic acid; BAS, bile acid sequestrant; BID, twice daily; CAI, cholesterol absorption inhibitor; CV, cardiovascular; HMG CoA; 3-hydroxy-3-methylglutaryl-coenzyme A; LDL-C, low-density lipoprotein cholesterol; LDLR, low-density lipoprotein receptor; MAb, monoclonal antibody; MTP, microsomal triglyceride transfer protein; NPC1L1, Niemann-Pick C-like transporter; PCSK9, proprotein convertase subtilisin/kexin 9; PPAR, peroxisome proliferator-activated receptor; SC, subcutaneous; siRNA, short interfering ribonucleic acid; TG, triglyceride.

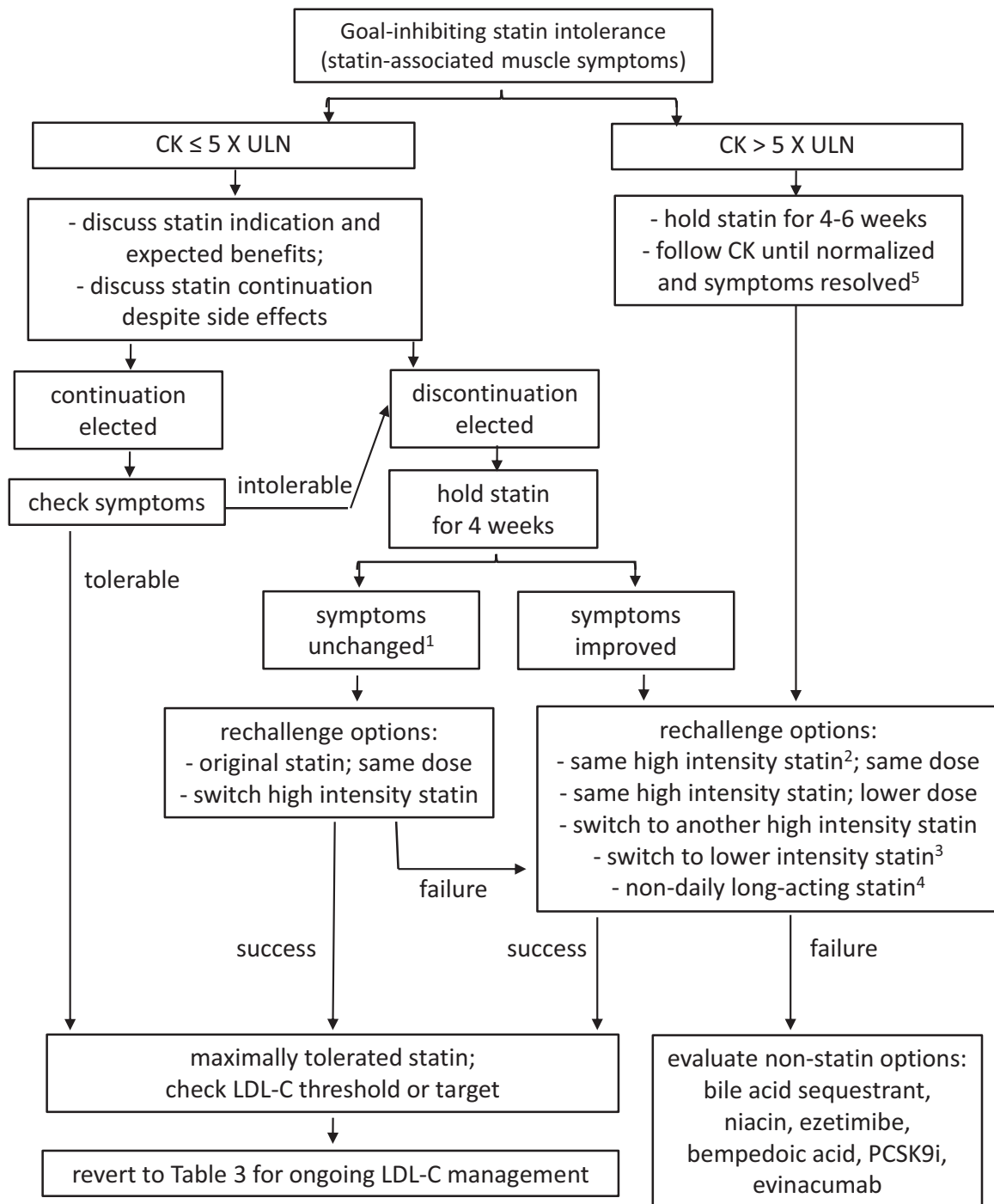

Figure 5. Approach to the patient with statin intolerance.

with renal impairment (264). Ezetimibe is a second-line agent in clinical practice guidelines (42-44) and is often prescribed to statin-intolerant patients.

PCSK9 inhibitors

PCSK9 is expressed by hepatocytes, circulates briefly in plasma, binds LDL receptors, and participates in receptor-mediated endocytosis of LDL particles (265). PCSK9 diverts the receptor-ligand complex away from its normal recycling

pathway toward lysosomal degradation (Fig. 1) (266). When PCSK9 is present, the liver loses capacity to clear LDL particles from the blood and LDL-C levels rise. Individuals with genetically impaired PCSK9 function have lower levels of circulating LDL-C and reduced lifetime ASCVD risk (267). PCSK9 is not accessible to oral agents, so targeting it requires biologic approaches, such as monoclonal antibodies or antisense RNA strategies (268).

Two monoclonal antibodies are currently available for clinical use: evolocumab (trade name Repatha;

Amgen) and alirocumab (trade name Praluent; Sanofi-Regeneron). These agents are typically administered subcutaneously every 2 weeks, although monthly dosing is available. Both agents reduce both LDL-C and ASCVD events when used in combination with a statin (269). Evolocumab induces regression and reversal of coronary arterial plaques (270). Indications for PCSK9 inhibitors include patients with FH and patients with ASCVD who are above target LDL-C levels despite statin and/or ezetimibe therapy. These agents are very well tolerated, with only occasional mild injection site reactions, and are worth considering in patients with appropriate clinical indications. However, because of cost considerations, some treatment algorithms suggest that these agents should be considered only after statin and ezetimibe have been tried (271).

Bile acid sequestrants

Bile acid sequestrants (BASs), such as cholestyramine, colestipol, and colesevelam, are orally administered basic anion-exchange resins that interrupt the enterohepatic recirculation, diverting hepatic cholesterol into bile synthesis and thus depleting intrahepatic cholesterol stores (272). The resulting upregulation of the LDL receptor increases LDL particle catabolism and decreases LDL-C levels. BASs have a complementary mechanism of action and are additive to the LDL-lowering effects of statins. A systematic review of 15 trials found that BASs decreased LDL-C levels by 15% over statin monotherapy (273). Despite evidence for reduction of ASCVD end points and a long safety record, compliance with BASs is poor because of adverse gastrointestinal effects. Because BASs raise serum TG, they must be avoided in individuals with HTG. BAS third-line agents at best for patients who fail to reach target LDL-C or who have statin intolerance.

Niacin

Niacin—or nicotinic acid—is a third-line oral agent used in patients with mild-to-moderate dyslipidemia. Niacin 2 to 3 g daily can lower plasma TG by up to 45%, raise plasma HDL-C by up to 25%, and reduce plasma LDL-C by up to 20% (274). After almost 6 decades of clinical use, niacin's mechanism of action remains unknown. Niacin often causes light-headedness, skin flushing, and pruritus. Other adverse effects include elevated liver enzymes, gastrointestinal upset, worsened glucose tolerance, and elevated uric acid. Adding extended-release niacin to statin therapy did not reduce ASCVD outcomes in 2 pivotal trials (62, 275). Thus, niacin is no longer recommended in treatment guidelines and its use has declined.

Lomitapide

Lomitapide is a daily oral medication that was developed for the treatment of biallelic hypercholesterolemia (homozygous FH [HoFH]) (276). Lomitapide lowers LDL-C and TG each by 40% to 50% by directly inhibiting assembly of apo B-containing lipoproteins in the liver and intestine (277, 278). Fatty liver is a mechanism-based adverse effect (279). However, ~25% of patients in short-term studies developed transaminase elevations and accumulation of hepatic fat, although this became less severe with prolonged treatment (280). Fat-soluble vitamin supplements are often included with lomitapide treatment.

Extracorporeal LDL-C removal

Extracorporeal removal of lipoproteins is achieved through either weekly or biweekly nonspecific serial plasma exchange plasma exchange or plasmapheresis, or specific targeted approaches to remove LDL or Lp(a) such as size exclusion columns or antibody-based affinity columns (reviewed in (281, 282)). There are no randomized ASCVD outcomes trials with any of these methods, and their use varies widely, mainly to manage the lipid disturbances in severe hypercholesterolemia, especially biallelic hypercholesterolemia (HoFH) or elevated Lp(a). Untreated HoFH has been associated with premature mortality because patients have virtually no functional LDL receptors to upregulate, and statins have little to no effect (132). The mainstay of treatment in HoFH is one of several extracorporeal approaches to remove the accumulating LDL particles. Apheresis has prolonged the atherosclerosis-free survival of HoFH patients (283), who now live long enough to have manifestation of unexpected cardiovascular disease end points, specifically aortic root and valvular calcification, often requiring surgical replacement. Future use of apheresis may be reduced by some newer agents discussed in the following section.

TG-lowering agents

Fibric acid derivatives (fibrates). Fibric acid derivatives or fibrates, such as gemfibrozil, fenofibrate, bezafibrate, and ciprofibrate can reduce plasma TG by up to 50%, and can raise plasma HDL-C by up to 20%. Fibrates modulate activity of hepatic peroxisome proliferator-activated receptor- α , down-regulating apo C-III expression and up-regulating apo A-I, fatty acid oxidation, and LPL activity, thereby increasing fatty acid oxidation and reducing VLDL production. Because their LDL-lowering is modest and because recent clinical trials show little to no benefit of fibrates added to statin therapy for ASCVD risk reduction in patients with normal to mildly increased TG

levels (284), fibrate use is mainly reserved for treatment of patients with severe HTG to reduce risk of acute pancreatitis (285). Fibrates can also be considered as add-on therapy for patients with high ASCVD risk who may need a second agent because TG remains markedly elevated. An ongoing randomized clinical trial of pemafibrate—a novel selective peroxisome proliferator activated receptor modulator (286)—has enrolled statin-treated patients with type 2 diabetes and TG between 2.3 and 5.4 mmol/L (200 and 475 mg/dL) (287). This event-driven study anticipates 1092 adjudicated primary end points, allow for detection of an 18% reduction in the primary ASCVD endpoint, with results expected in 2024.

N-3 (omega-3) fatty acids

Omega-3 fatty acids such as eicosapentaenoic acid modestly lower triglyceride levels by inhibiting de novo lipogenesis through suppression of sterol regulatory element-binding protein genes and by increasing both fatty acid oxidation and triglyceride catabolism through nonspecific activation of peroxisome proliferator activated receptor gene family members (288).

Omega-3 fatty acid preparations have inconsistent evidence of reduction of ASCVD risk (289). In 2018, the multinational Reduction of Cardiovascular Events With Icosapent Ethyl – Intervention Trial of icosapent ethyl, which is purified eicosapentaenoic acid, showed a 25% relative risk reduction in primary ASCVD end point, corresponding to a number needed to treat in 21 patients to prevent 1 event (173). A comparable study that used a mixture of omega-3 fatty acids was negative with respect to ASCVD outcomes (290), suggesting that purified EPA might have unique and pleiotropic effects to reduce ASCVD risk. Current treatment guidelines now advise that for statin-treated patients with residual HTG up to 5.6 mmol/L (500 mg/dL), icosapent ethyl 4 g daily can be added to further reduce risk of ASCVD events (42-44). However, other types of omega-3 preparations, including

over-the-counter supplements are explicitly advised against in this context (43).

Abandoned treatments

Several treatments for dyslipidemia have been abandoned for various reasons, as summarized in Table 9.

New and emerging therapies for dyslipidemia

We live in a golden age of discovery and development of new therapies for dyslipidemias, of which inhibit molecular targets that normally act to increase plasma lipid levels. Inhibition platforms range from traditional small molecule oral inhibitors, to monoclonal antibodies targeting circulating proteins, to short interfering RNA and antisense RNA agents that impair translation of the deleterious protein product of the targeted gene. Other platforms such as gene editing and gene transfer will not be discussed here. For a detailed discussion of emerging treatments, the reader is referred to a recent review (291). Here, we overview certain drugs that have potential in the near term to increase options for patients and health care providers.

Bempedoic acid

Bempedoic acid (Esperion, Ann Arbor, MI) is an oral small molecule that acts in the cholesterol biosynthetic pathway interfering with ATP-citrate lyase upstream of HMGCR (292). Bempedoic acid 180 mg daily reduces LDL-C by 15% to 20% from baseline either as monotherapy or when taken with background statin therapy. When bempedoic acid 180 mg daily and ezetimibe 10 mg daily were taken together, LDL-C was reduced by 50% (293). Although serious side effects have not been reported to date, blinded clinical trial patients randomized to receive bempedoic acid were more likely to discontinue treatment, often because of headaches (293).

Table 9. Abandoned treatments for dyslipidemia

Treatment name	Mechanism of action	Year and reason development was abandoned
Mipomersen (trade name Kynamro)	Anti-apo B ASO	2016; adverse effects including skin reactions and hepatotoxicity
Torcetrapib	CETP inhibitor	2006; increased mortality in randomized trials
Evacetrapib	CETP inhibitor	2015; neutral effects in randomized trials
Anacetrapib	CETP inhibitor	2017; no obvious commercial path forward despite positive CV outcomes trial
Alipogene tiparvovec (trade name Glybera)	LPL gene therapy	2017; no obvious commercial path forward
Pradigastat	DGAT inhibitor	2017; adverse gastrointestinal effects

Abbreviations: ASO, antisense oligonucleotide; CETP, cholesterol ester transfer protein; CV, cardiovascular; DGAT, diacylglycerol acyltransferase.

Bempedoic acid was approved in 2020 by the FDA for LDL-C reduction both as monotherapy 180 mg (trade name Nexletol in the United States, Nilemdo in the EU [Esperion]) and in combination with ezetimibe 10 mg (trade name Nexlizet in the United States, Nustendi in the EU [Esperion]) (294). Potential indications for bempedoic alone and in combination with ezetimibe or PCSK9 inhibitors include helping patients achieve lower LDL-C than is possible while taking the maximally tolerated statin dose. A large cardiovascular outcome study of bempedoic acid in patients with statin intolerance has been initiated (295).

Inclisiran

Inclisiran (trade name Leqvio, Novartis) is a small interfering RNA (siRNA) against PCSK9 conjugated to triantennary N-acetylgalactosamine (GalNAc) administered subcutaneously that reduces LDL cholesterol by 50% to 60%. Inclisiran's siRNA-based mechanism of inhibiting PCSK9 differs from monoclonal antibodies because it interferes with intracellular PCSK9 before its secretion (296). Also, inclisiran does not interact directly with LDL particles or LDL receptors. Inclisiran is notable for its long duration of action, with sustained reductions of both circulating PCSK9 and LDL-C persisting between 6 and 12 months after a single injection (296). Data from a total of 3660 patients from 3 randomized clinical trials—2 in ASCVD patients and 1 in heterozygous FH patients—showed that inclisiran reduced LDL-C by 51% (95% CI, 48–53, $P < 0.001$), and TC, non-HDL-C, and apo B by 37%, 45%, and 41%, respectively, compared with placebo (297). Meta-analysis showed that inclisiran reduced risk of major ASCVD events: risk ratio 0.76 (95% CI, 0.61–0.92, $P < 0.01$) (297). Besides an increase in mild injection site reactions, adverse effects were not different between groups (297).

Inclisiran was approved in the European Union in December 2020 and in Canada in July 2021 for use in adults with primary hypercholesterolemia, either FH or nonfamilial, or with mixed dyslipidemia, as an adjunct to diet. A unique but controversial collaboration between the National Health Service in the United Kingdom and inclisiran's manufacturer is in the midst of developing a plan for launching the drug (298). If inclisiran's indication can be expanded to reduction of ASCVD end points, and if cost is reasonable, it will likely be useful in many clinical situations, including in patients with FH and/or established or high ASCVD risk with recalcitrant LDL-C levels, statin-intolerant patients, and noncompliant patients. A large-scale prospective cardiovascular outcomes study of inclisiran is currently ongoing (299).

Gemcabene

Gemcabene calcium (Gemphire Therapeutics, Ann Arbor, MI) is an oral small molecule, with a symmetrical molecular structure including dicarboxylic acid and 2 terminal gem dimethyl carboxylate moieties (291). Gemcabene is being developed as first-in-class agent: the 300- and 900-mg daily doses reduced LDL-C by 23% and 28%, respectively, over background statin therapy. Gemcabene reduced LDL-C in patients with biallelic hypercholesterolemia (HoFH) by ~30% (300). If approved, potential indications for gemcabene would be similar to those for bempedoic acid.

Targeting apolipoprotein C-III: volanesorsen; AKCEA-APOCIII-LRx; AROAPOC3

Apo C-III is a 79 amino acid protein expressed in the liver and intestine and is a component of TG-rich lipoproteins (301). Apo C-III has pleiotropic effects in lipoprotein metabolism (302), and human genetic studies have solidified apo C-III as a treatment target both for both severe and mild-to-moderate HTG to prevent acute pancreatitis and ASCVD, respectively (303).

The first agent developed to target apo C-III was the antisense oligonucleotide (ASO) RNA drug volanesorsen (Waylivra, Akcea Pharmaceuticals) (304). Two phase 3 multicenter, randomized, double-blind, placebo-controlled clinical trials of volanesorsen have been published: APPROACH—A Study of ISIS 304801 in Patients With Familial Chylomicronemia Syndrome ($N = 66$) (184) and COMPASS—A Study of Volanesorsen in Patients With Hypertriglyceridemia ($N = 114$) (305). Results were comparable in these 2 studies: at 3 months, patients on volanesorsen had -77% and -71% decreases in plasma TG levels, respectively, as well as favorable changes on the rest of the lipid profile (184, 305). Although not powered to address prophylaxis of acute pancreatitis, reduced frequency of events was observed across the 2 studies in patients receiving volanesorsen. However, among patients with FCS, volanesorsen was associated with risk of thrombocytopenia, which was profound in a few cases (305). In August 2018, the US FDA announced that it did not approve volanesorsen (185). The European Medicines Agency, in contrast, has approved volanesorsen for FCS with some caveats (183). Thrombocytopenia appears to be a drug-specific side effect (183), rather than a class effect of all agents that target apo C-III.

Development of a next-generation GalNAc-conjugated ASO targeting apo C-III, namely AKCEA-APOCIII-LRx, appears to mitigate thrombocytopenia risk while preserving beneficial effects (306). Also, a promising siRNA molecule called AROAPOC3 (Arrowhead Pharmaceuticals) that is

currently in early-phase clinical trials may avoid this risk while retaining the metabolic benefits of targeting apo C-III (307).

Targeting ANPTL3: evinacumab, vupanorsen and AROANG3

ANGPTL3 is a liver-derived protein that broadly regulates lipid metabolism, primarily through inhibiting plasma lipases (308). Loss-of function mutations in *ANGPTL3* cause familial combined hypolipidemia (309), in which patients have pan-hypolipidemia, along with reduced ASCVD risk and no obvious detrimental effects (310). This genetic “experiment of nature” supports the idea that knocking down ANGPTL3 will have clinical benefits. Three approaches to reduce ANGPTL3 levels in early clinical development include: the monoclonal antibody evinacumab (trade name Evkeeza, Regeneron), the ASO vupanorsen (IONIS-ANGPTL3-LRx, Akcea and Pfizer), and the siRNA AROANG3 (Arrowhead Pharmaceuticals) (Table 10).

The mechanism whereby ANGPTL3 inhibition lowers LDL-C is unclear, but must be independent of the LDL receptor (311) because evinacumab 15 mg/kg given IV every 4 weeks in the ELIPSE HoFH trial reduced LDL-C in biallelic hypercholesterolemia (HoFH) patients by 47% (312). Patients with the most severe biallelic null *LDLR* gene mutations had a mean 41% reduction in LDL-C (312).

Evinacumab 450 mg given subcutaneously weekly lowered LDL-C by 56% over background therapy in patients with severe refractory hypercholesterolemia, with and without FH (313). No adverse effects have been noted so far in these small, short-term studies of evinacumab. Given the paucity of effective treatment options in homozygous FH, evinacumab is promising, especially because frequency of apheresis treatments can likely be reduced. Evinacumab was approved in February 2021 by the US FDA as an adjunct to other LDL-C-lowering therapies for adult and pediatric patients >12 years with homozygous FH, but not without controversy in light of its hefty price tag (314). It also received a positive opinion in 2021 from the European Medicines Agency. The efficacy and potential role of evinacumab in FCS and severe HTG are under evaluation, but preliminary reports appear promising (315).

Vupanorsen is a GalNac-modified ASO targeting ANGPTL3 which in a dose-ranging study in patients with mild hypertriglyceridemia and fatty liver showed reductions in plasma TG and LDL cholesterol of 44% and 7%, respectively, with no safety signals (187). Early efficacy studies of the siRNA AROANG3 apparently show similar efficacy across the lipoprotein profile (316).

The eventual clinical use of anti-ANGPTL3 agents remains to be determined. Although evinacumab’s efficacy in LDL-C reduction in biallelic hypercholesterolemia (HoFH)

Table 10. Emerging treatments

Class	Agent	Dose	Mechanism of action	Main indication	Comments
ANGPTL3 inhibitors	Evinacumab	15 mg/kg IV every 4 weeks	Global lipid reduction	LDL-C reduction in HoFH; TG reduction	↓ LDL-C by 30%-50% and ↓ TG by 25%-45%
	Vupanorsen	40-80 mg SC every 4 weeks	Global lipid reduction	LDL-C reduction in HoFH; TG reduction	↓ LDL-C by 30%-50% and ↓ TG by 25%-45%
	AROANG3	50-200 mg SC every 2-4 weeks	Global lipid reduction	LDL-C reduction in HoFH; TG reduction	↓ LDL-C by 30%-50% and ↓ TG by 25%-45%
Apo C-III inhibitors	Volanesorsen	300 mg SC every 1 week	ASO knocks down apo C-III	TG reduction	↓ TG by 50%-70%
	AKCEA-apoC3-LRX	Undetermined	ASO knocks down apo C-III	TG reduction	↓ TG by 50%-70%; GalNac linked
	AROPOC3	50 mg SC every 12 weeks	siRNA knocks down apo C-III	TG reduction	↓ TG by 50%-70%
anti-Lp(a)	Olpasiran	Undetermined	siRNA knocks down Lp(a)	Lp(a) reduction	↓ Lp(a) by 50%-70%
	Pelacarsen	80 mg SC every 4 weeks	ASO knocks down Lp(a)	Lp(a) reduction	↓ Lp(a) by 50%-70%
Other	Gemcabene	300-900 mg/d	Unclear	LDL-C reduction	↓ LDL-C by 15%-25% as monotherapy or added to statin

Abbreviations: ANGPTL3, angiopoietin-like protein 3; apo, apolipoprotein; ASO, antisense oligonucleotide; GalNac, conjugated with N-acetylgalactosamine; HoFH, homozygous familial hypercholesterolemia; LDL-C, low-density lipoprotein cholesterol; Lp(a), lipoprotein(a); SC, subcutaneous; siRNA, small interfering RNA; TG, triglyceride.

and refractory severe hypercholesterolemia are notable, the utility of this approach in severe HTG requires more study. It is worth keeping an eye on the possible effect of ANGPTL3 inhibition in FCS patients with complete absence of plasma lipolytic activity because ANGPTL3 requires functional lipases (308). It would be of interest to compare efficacy of targeting APOC3 head-to-head vs ANGPTL3 in patients with severe HTG. Another potential target group for ANGPTL3 inhibition are patients with combined dyslipidemia.

Other targets for hypertriglyceridemia

Additional potential treatment targets for patients with HTG include apo C-II and ANGPTL4. Apo C-II is a cofactor for LPL, and complete deficiency accounts for 2% to 5% of FCS cases (34), with ~20 reported human mutations (12). This very rare subgroup of patients might theoretically benefit from infusion of an apo C-II peptide that is under development (317).

Similar to ANGPTL3, ANGPTL4 regulates LPL activity (308). But targeting ANGPTL4 with a monoclonal antibody in preclinical models was associated with mesenteric adenitis, which has curbed enthusiasm for pursuing this target in humans (318).

Lp(a) as a target

Elevated Lp(a) levels are an ASCVD risk factor across numerous patient demographics and geographic ancestries (319), as well as in patients treated with statins and PCSK9 inhibitors (320). The Lp(a) particle resembles LDL, but is independently regulated and metabolized (321). Both niacin and serial apheresis treatments were previously recommended to reduce Lp(a) but each has significant drawbacks and neither reduced ASCVD events (322). PCSK9 inhibitors—both monoclonal antibodies and inclisiran—lower Lp(a) by 26%, but this is insufficient for individuals with very high Lp(a) levels (265). A GalNAc-linked ASO against Lp(a) (TQJ230, trade name pelacarsen, Novartis) reduces its levels by 80% to 90% with no effect on other variables (323); this agent is being evaluated in a large randomized of secondary prevention of ASCVD in individuals with elevated Lp(a) levels (324). An siRNA compound aimed at reducing apo(a) synthesis (AMG 890, trade name olpasiran, Amgen) is also under investigation. Depending on results of outcome trials, these agents could be helpful for patients with elevated Lp(a) levels.

HDL as a target

HDL has been demoted as a therapeutic target based on a preponderance of genetic and clinical trial evidence (209), although HDL-C levels remain excellent predictors

of ASCVD risk. But because of failure of clinical trials of numerous HDL-raising therapies, such as oral inhibitors of CETP (325) and long-acting niacin (284), drug development has focused on apo B-containing lipoproteins and remnant particles, rather than HDL-raising. Similarly, infusion of HDL mimetics or apo A-I peptides has not proven to be beneficial with respect to ASCVD risk reduction (326), although clinical trials of this approach are ongoing. It remains possible that HDL function rather than quantity will prove to be a clinically relevant target (211). An interesting development has been pursuit of a pharmacogenetic hypothesis, namely that 30% of the population who are homozygous for the A allele of the rs1967309 SNP in the *ADCY9* gene will respond preferentially to treatment with the CETP inhibitor dalcetrapib (327); the DAL-GENE trial will be reporting within 2 years (328).

In contrast to pursuing HDL-raising for ASCVD protection in the general population, there is ongoing drug development activity for rare patients with monogenic conditions of low to absent HDL-C. For instance, for patients with *LCAT* deficiency (219), treatments in development include enzyme replacement therapy, liver-directed gene therapy, engineered cell therapies, and infused peptides (for review, see (329)). Patients with Tangier disease likewise represent a priority for development of orphan treatments targeting ATP binding cassette transporter A1 (217). Similarly, for rare patients with apo A-I deficiency, there remain active drug development programs (218), especially for the subgroup of these patients that develops systemic amyloidosis (63).

Summary

Recently accelerating advances in our understanding of the genetics and metabolism of lipoproteins are rapidly being translated into available new diagnostic tools, such as next-generation sequencing, along with new biologic therapies to specifically target molecules of central metabolic importance. Perhaps counterintuitively, these scientific advances have allowed for a streamlined overall approach to classification and management of patients with dyslipidemias (ie, hypercholesterolemia, hypertriglyceridemia, combined dyslipidemia, or other).

Hypercholesterolemia is due primarily to elevated LDL-C and is managed according to evidence-based guideline threshold values to prevent ASCVD maximizing the use of established treatments such as statins, ezetimibe, and monoclonal antibodies against PCSK9 inhibitors. New agents such as inclisiran, bempedoic acid, and evinacumab are poised to fill currently unmet clinical needs. For hypertriglyceridemia, evidence that intervention will prevent ASCVD is currently limited

to icosapent ethyl and possibly fibrates in high TG subgroups of statin-treated patients; pending clinical trials will permit more definitive advice. However, reduction of severely elevated TG levels to reduce pancreatitis risk is less contentious; new agents targeting apo C-III will play an important role in treatment of these patients, and perhaps even more broadly for ASCVD prevention in patients with milder HTG. Agents targeting ANGPTL3 may show similar clinical utility in HTG patients, but also provide additional hope of normalizing the broader disturbances in patients with combined dyslipidemia. Utility of agents targeting Lp(a) will depend on cardiovascular outcome trials.

Today's practitioner has much to offer the patient with dyslipidemia. The routine lipid profile is very helpful in establishing the parameters for proceeding with treatment. Additional tests such as apo B and Lp(a) can help with more precise stratification of ASCVD risk and apo B can even be serially monitored to gauge efficacy of treatment. Genetic testing is not essential for most patients with dyslipidemia, but may be helpful in selected instances when there is strong clinical suspicion of such conditions as FH and FCS. But despite the technological advances, traditional diligence regarding ruling out secondary factors, encouraging a prudent diet, exercise, and weight loss, along with global ASCVD risk factor control remain the cornerstones of dyslipidemia management in our brave new world of next-generation sequencing and therapeutic RNA interference.

Additional Information

Correspondence: Robert Hegele, MD, FRCPC, Cert Endo, FACP, Robarts Research Institute, Schulich School of Medicine and Dentistry, Western University, 4288A - 1151 Richmond St., London, ON, Canada, N6A 5B7. Email: hegele@robarts.ca.

Financial Support: R.A.H. is supported by the Jacob J. Wolfe Distinguished Medical Research Chair, the Edith Schulich Vinet Research Chair in Human Genetics, and the Martha G. Blackburn Chair in Cardiovascular Research. R.A.H. has also received operating grants from the Canadian Institutes of Health Research (Foundation award), the Heart and Stroke Foundation of Ontario (G-21-0031455) and the Academic Medical Association of Southwestern Ontario (INN21-011).

Disclosures: R.A.H. reports consulting fees from Acasti, Aegerion, Akcea/Ionis, Amgen, Arrowhead, HLS Therapeutics, Novartis, Pfizer, Regeneron and Sanofi.

REFERENCES

1. Hegele RA. Plasma lipoproteins: genetic influences and clinical implications. *Nat Rev Genet.* 2009;10(2):109-121.
2. Rosenson RS, Brewer HB Jr, Chapman MJ, et al. HDL measures, particle heterogeneity, proposed nomenclature, and relation to atherosclerotic cardiovascular events. *Clin Chem.* 2011;57(3):392-410.
3. Altmann SW, Davis HR Jr, Zhu LJ, et al. Niemann-Pick C1 Like 1 protein is critical for intestinal cholesterol absorption. *Science.* 2004;303(5661):1201-1204.
4. Sato R, Takano T. Regulation of intracellular cholesterol metabolism. *Cell Struct Funct.* 1995;20(6):421-427.
5. Kang S, Davis RA. Cholesterol and hepatic lipoprotein assembly and secretion. *Biochim Biophys Acta.* 2000;1529(1-3):223-230.
6. Howles PN. Cholesterol absorption and metabolism. *Methods Mol Biol.* 2016;1438:177-197.
7. Cifarelli V, Abumrad NA. Intestinal CD36 and other key proteins of lipid utilization: role in absorption and gut homeostasis. *Compr Physiol.* 2018;8(2):493-507.
8. Alves-Bezerra M, Cohen DE. Triglyceride metabolism in the liver. *Compr Physiol.* 2017;8(1):1-8.
9. Sirwi A, Hussain MM. Lipid transfer proteins in the assembly of apoB-containing lipoproteins. *J Lipid Res.* 2018;59(7):1094-1102.
10. Hussain MM. Intestinal lipid absorption and lipoprotein formation. *Curr Opin Lipidol.* 2014;25(3):200-206.
11. Levy E, Poinsot P, Spahis S. Chylomicron retention disease: genetics, biochemistry, and clinical spectrum. *Curr Opin Lipidol.* 2019;30(2):134-139.
12. Brahm AJ, Hegele RA. Chylomicronaemia—current diagnosis and future therapies. *Nat Rev Endocrinol.* 2015;11(6):352-362.
13. Young SG, Fong LG, Beigneux AP, et al. GPIHBP1 and lipoprotein lipase, partners in plasma triglyceride metabolism. *Cell Metab.* 2019;30(1):51-65.
14. Wolska A, Dunbar RL, Freeman LA, et al. Apolipoprotein C-II: new findings related to genetics, biochemistry, and role in triglyceride metabolism. *Atherosclerosis.* 2017;267:49-60.
15. Au DT, Strickland DK, Muratoglu SC. The LDL receptor-related protein 1: at the crossroads of lipoprotein metabolism and insulin signaling. *J Diabetes Res.* 2017;2017:8356537.
16. Tosheska Trajkovska K, Topuzovska S. High-density lipoprotein metabolism and reverse cholesterol transport: strategies for raising HDL cholesterol. *Anatol J Cardiol.* 2017;18(2):149-154.
17. Garuti R, Jones C, Li WP, et al. The modular adaptor protein autosomal recessive hypercholesterolemia (ARH) promotes low density lipoprotein receptor clustering into clathrin-coated pits. *J Biol Chem.* 2005;280(49):40996-41004.
18. Lagace TA. PCSK9 and LDLR degradation: regulatory mechanisms in circulation and in cells. *Curr Opin Lipidol.* 2014;25(5):387-393.
19. Zhang H. Lysosomal acid lipase and lipid metabolism: new mechanisms, new questions, and new therapies. *Curr Opin Lipidol.* 2018;29:218-223.
20. Feingold KR. Introduction to lipids and lipoproteins. In: Feingold KR, Anawalt B, Boyce A, et al., eds. *Endotext [Internet]*. MDText.com, Inc; 2000. <https://www.ncbi.nlm.nih.gov/books/NBK305896/>
21. Wang S, Smith JD. ABCA1 and nascent HDL biogenesis. *Biofactors.* 2014;40(6):547-554.
22. Shen WJ, Azhar S, Kraemer FB. SR-B1: a unique multifunctional receptor for cholesterol influx and efflux. *Annu Rev Physiol.* 2018;80:95-116.

23. Zhao B, Song J, Ghosh S. Hepatic overexpression of cholesteryl ester hydrolase enhances cholesterol elimination and in vivo reverse cholesterol transport. *J Lipid Res.* 2008;**49**(10):2212-2217.
24. Chiang JY. Bile acids: regulation of synthesis. *J Lipid Res* 2009;**50**:1955-1966.
25. Fredrickson DS, Lees RS. A system for phenotyping hyperlipoproteinemia. *Circulation.* 1965;**31**:321-327.
26. Hegele RA, Pollex RL. Hypertriglyceridemia: phenomics and genomics. *Mol Cell Biochem.* 2009;**326**(1-2):35-43.
27. Wang J, Ban MR, Kennedy BA, et al. APOA5 genetic variants are markers for classic hyperlipoproteinemia phenotypes and hypertriglyceridemia. *Nat Clin Pract Cardiovasc Med.* 2008;**5**(11):730-737.
28. Hegele RA, Ban MR, Hsueh N, et al. A polygenic basis for four classical Fredrickson hyperlipoproteinemia phenotypes that are characterized by hypertriglyceridemia. *Hum Mol Genet.* 2009;**18**(21):4189-4194.
29. Johansen CT, Wang J, Lanktree MB, et al. An increased burden of common and rare lipid-associated risk alleles contributes to the phenotypic spectrum of hypertriglyceridemia. *Arterioscler Thromb Vasc Biol.* 2011;**31**:1916-1926.
30. Hegele RA, Dron JS. 2019 George Lyman Duff Memorial Lecture: three decades of examining DNA in patients with dyslipidemia. *Arterioscler Thromb Vasc Biol.* 2020;**40**:1970-1981.
31. Gill PK, Dron JS, Berberich AJ, et al. Combined hyperlipidemia is genetically similar to isolated hypertriglyceridemia. *J Clin Lipidol.* 2021;**15**(1):79-87.
32. Dron JS, Wang J, McIntyre AD, Cao H, Hegele RA. The polygenic nature of mild-to-moderate hypertriglyceridemia. *J Clin Lipidol.* 2020;**14**:28-34 e22.
33. Dron JS, Wang J, Cao H, et al. Severe hypertriglyceridemia is primarily polygenic. *J Clin Lipidol.* 2019;**13**(1):80-88.
34. Hegele RA, Berberich AJ, Ban MR, et al. Clinical and biochemical features of different molecular etiologies of familial chylomicronemia. *J Clin Lipidol.* 2018;**12**:920-927 e924.
35. Wang J, Dron JS, Ban MR, et al. Polygenic versus monogenic causes of hypercholesterolemia ascertained clinically. *Arterioscler Thromb Vasc Biol.* 2016;**36**(12):2439-2445.
36. Garg A, Garg V, Hegele RA, Lewis GF. Practical definitions of severe versus familial hypercholesterolaemia and hypertriglyceridaemia for adult clinical practice. *Lancet Diabetes Endocrinol.* 2019;**7**(11):880-886.
37. Langlois MR, Nordestgaard BG, Langsted A, et al.; European Atherosclerosis Society (EAS) and the European Federation of Clinical Chemistry and Laboratory Medicine (EFLM) Joint Consensus Initiative. Quantifying atherogenic lipoproteins for lipid-lowering strategies: consensus-based recommendations from EAS and EFLM. *Clin Chem Lab Med.* 2020;**58**(4):496-517.
38. Baigent C, Blackwell L, Emberson J, et al.; Cholesterol Treatment Trialists' (CTT) Collaboration. Efficacy and safety of more intensive lowering of LDL cholesterol: a meta-analysis of data from 170 000 participants in 26 randomised trials. *Lancet.* 2010;**376**(9753):1670-1681.
39. Wang N, Fulcher J, Abeysuriya N, et al. Intensive LDL cholesterol-lowering treatment beyond current recommendations for the prevention of major vascular events: a systematic review and meta-analysis of randomised trials including 327 037 participants. *Lancet Diabetes Endocrinol.* 2020;**8**:36-49.
40. Estruch R, Martínez-González MA, Corella D, et al. Effect of a high-fat Mediterranean diet on bodyweight and waist circumference: a prespecified secondary outcomes analysis of the PREDIMED randomised controlled trial. *Lancet Diabetes Endocrinol.* 2016;**4**:e8. doi:10.1016/S2213-8587(16)30041-9.
41. Brunham LR, Ruel I, Aljenedil S, et al. Canadian cardiovascular society position statement on familial hypercholesterolemia: update 2018. *Can J Cardiol.* 2018;**34**(12):1553-1563.
42. Grundy SM, Stone NJ, Bailey AL, et al. 2018 AHA/ACC/AACVPR/AAPA/ABC/ACPM/ADA/AGS/APhA/ASPC/NLA/PCNA Guideline on the Management of Blood Cholesterol: a report of the American College of Cardiology/American Heart Association Task Force on Clinical Practice Guidelines. *Circulation.* 2019;**139**(25):e1082-e1143.
43. Pearson GJ, Thanassoulis G, Anderson TJ, et al. 2021 Canadian Cardiovascular Society Guidelines for the Management of Dyslipidemia for the Prevention of Cardiovascular Disease in Adults. *Can J Cardiol.* 2021;**37**(8):1129-1150.
44. Mach F, Baigent C, Catapano AL, et al.; Group ESCSD. 2019 ESC/EAS Guidelines for the management of dyslipidaemias: lipid modification to reduce cardiovascular risk. *Eur Heart J* 2020;**41**:111-188.
45. Berglund L, Brunzell JD, Goldberg AC, et al.; Endocrine society. Evaluation and treatment of hypertriglyceridemia: an Endocrine Society clinical practice guideline. *J Clin Endocrinol Metab.* 2012;**97**(9):2969-2989.
46. Hegele RA, Ginsberg HN, Chapman MJ, et al.; European Atherosclerosis Society Consensus Panel. The polygenic nature of hypertriglyceridaemia: implications for definition, diagnosis, and management. *Lancet Diabetes Endocrinol.* 2014;**2**(8):655-666.
47. Expert Panel on Detection, Evaluation, and Treatment of High Blood Cholesterol in Adults. Executive Summary of The Third Report of The National Cholesterol Education Program (NCEP) Expert Panel on Detection, Evaluation, And Treatment of High Blood Cholesterol In Adults (Adult Treatment Panel III). *JAMA* 2001;**285**:2486-2497.
48. Genest JJ, Jr., Martin-Munley SS, McNamara JR, et al. Familial lipoprotein disorders in patients with premature coronary artery disease. *Circulation.* 1992;**85**:2025-2033.
49. Meshkini M, Alaei-Shahmiri F, Mamotte C, Earnest J. Ethnic variation in lipid profile and its associations with body composition and diet: differences between Iranians, Indians and Caucasians living in Australia. *J Immigr Minor Health.* 2017;**19**(1):67-73.
50. Tyroler HA, Glueck CJ, Christensen B, Kwiterovich PO, Jr. Plasma high-density lipoprotein cholesterol comparisons in black and white populations. The Lipid Research Clinics Program Prevalence Study. *Circulation.* 1980;**62**:IV99-IV107.
51. Kamstrup PR. Lipoprotein(a) and cardiovascular disease. *Clin Chem.* 2021;**67**(1):154-166.
52. Report of the National Cholesterol Education Program Expert Panel on Detection, Evaluation, and Treatment of High Blood Cholesterol in Adults. The Expert Panel. *Arch Intern Med.* 1988;**148**:36-69.
53. Grundy SM, Bilheimer D, Chait A, et al. Summary of the second report of the National Cholesterol Education Program (NCEP)

- expert panel on detection, evaluation, and treatment of high blood cholesterol in adults (adult treatment panel II). *JAMA* 1993;269:3015-3023.
54. Iuliano L, Mauriello A, Sbarigia E, Spagnoli LG, Violi F. Radiolabeled native low-density lipoprotein injected into patients with carotid stenosis accumulates in macrophages of atherosclerotic plaque: effect of vitamin E supplementation. *Circulation*. 2000;101(11):1249-1254.
 55. Podrez EA, Febbraio M, Sheibani N, et al. Macrophage scavenger receptor CD36 is the major receptor for LDL modified by monocyte-generated reactive nitrogen species. *J Clin Invest*. 2000;105(8):1095-1108.
 56. Rader DJ, Cohen J, Hobbs HH. Monogenic hypercholesterolemia: new insights in pathogenesis and treatment. *J Clin Invest*. 2003;111(12):1795-1803.
 57. Lusis AJ. Atherosclerosis. *Nature*. 2000;407(6801):233-241.
 58. National Cholesterol Education Program (NCEP) Expert Panel on Detection, Evaluation, and Treatment of High Blood Cholesterol in Adults (Adult Treatment Panel III). Third Report of the National Cholesterol Education Program (NCEP) Expert Panel on Detection, Evaluation, and Treatment of High Blood Cholesterol in Adults (Adult Treatment Panel III) final report. *Circulation*. 2002;106:3143-3421.
 59. Yusuf S, Hawken S, Ounpuu S, et al.; INTERHEART Study Investigators. Effect of potentially modifiable risk factors associated with myocardial infarction in 52 countries (the INTERHEART study): case-control study. *Lancet*. 2004;364(9438):937-952.
 60. McQueen MJ, Hawken S, Wang X, et al.; INTERHEART study investigators. Lipids, lipoproteins, and apolipoproteins as risk markers of myocardial infarction in 52 countries (the INTERHEART study): a case-control study. *Lancet*. 2008;372(9634):224-233.
 61. Voight BF, Peloso GM, Orho-Melander M, et al. Plasma HDL cholesterol and risk of myocardial infarction: a mendelian randomisation study. *Lancet*. 2012;380(9841):572-580.
 62. Boden WE, Probstfield JL, Anderson T, et al.; AIM-HIGH Investigators. Niacin in patients with low HDL cholesterol levels receiving intensive statin therapy. *N Engl J Med*. 2011;365(24):2255-2267.
 63. Jeraj N, Hegele RA, Berberich AJ. Apolipoprotein genetic variants and hereditary amyloidosis. *Curr Opin Lipidol*. 2021;32(2):132-140.
 64. Dron JS, Hegele RA. Ischemic event reduction and triglycerides. *J Am Coll Cardiol*. 2019;74(14):1848-1849.
 65. Rosenson RS, Davidson MH, Hirsh BJ, Kathiresan S, Gaudet D. Genetics and causality of triglyceride-rich lipoproteins in atherosclerotic cardiovascular disease. *J Am Coll Cardiol*. 2014;64:2525-2540.
 66. Sarwar N, Sandhu MS, Ricketts SL, et al.; Triglyceride Coronary Disease Genetics Consortium and Emerging Risk Factors Collaboration. Triglyceride-mediated pathways and coronary disease: collaborative analysis of 101 studies. *Lancet*. 2010;375:1634-1639.
 67. Sarwar N, Danesh J, Eiriksdottir G, et al. Triglycerides and the risk of coronary heart disease: 10 158 incident cases among 262 525 participants in 29 Western prospective studies. *Circulation*. 2007;115(4):450-458.
 68. Haim M, Benderly M, Brunner D, et al. Elevated serum triglyceride levels and long-term mortality in patients with coronary heart disease: the Bezafibrate Infarction Prevention (BIP) Registry. *Circulation*. 1999;100(5):475-482.
 69. Pare G, Anand SS. Mendelian randomisation, triglycerides, and CHD. *Lancet*. 2010;375(9726):1584-1586.
 70. Holmes MV, Asselbergs FW, Palmer TM, et al.; UCLEB consortium. Mendelian randomization of blood lipids for coronary heart disease. *Eur Heart J*. 2015;36(9):539-550.
 71. Peng J, Luo F, Ruan G, Peng R, Li X. Hypertriglyceridemia and atherosclerosis. *Lipids Health Dis*. 2017;16(1):233.
 72. Goldberg IJ, Eckel RH, McPherson R. Triglycerides and heart disease: still a hypothesis? *Arterioscler Thromb Vasc Biol*. 2011;31(8):1716-1725.
 73. Laufs U, Parhofer KG, Ginsberg HN, Hegele RA. Clinical review on triglycerides. *Eur Heart J*. 2020;41:99-109c.
 74. Kramsch DM, Franzblau C, Hollander W. The protein and lipid composition of arterial elastin and its relationship to lipid accumulation in the atherosclerotic plaque. *J Clin Invest*. 1971;50(8):1666-1677.
 75. Tada H, Nohara A, Inazu A, Mabuchi H, Kawashiri MA. Remnant lipoproteins and atherosclerotic cardiovascular disease. *Clin Chim Acta*. 2019;490:1-5.
 76. Proctor SD, Vine DF, Mamo JC. Arterial retention of apolipoprotein B(48)- and B(100)-containing lipoproteins in atherogenesis. *Curr Opin Lipidol*. 2002;13(5):461-470.
 77. Mora S, Otvos JD, Rifai N, Rosenson RS, Buring JE, Ridker PM. Lipoprotein particle profiles by nuclear magnetic resonance compared with standard lipids and apolipoproteins in predicting incident cardiovascular disease in women. *Circulation*. 2009;119(7):931-939.
 78. Lewis GF, Xiao C, Hegele RA. Hypertriglyceridemia in the genomic era: a new paradigm. *Endocr Rev*. 2015;36(1):131-147.
 79. Wolska A, Yang ZH, Remaley AT. Hypertriglyceridemia: new approaches in management and treatment. *Curr Opin Lipidol*. 2020;31(6):331-339.
 80. Yang F, Wang Y, Sternfeld L, et al. The role of free fatty acids, pancreatic lipase and Ca⁺ signalling in injury of isolated acinar cells and pancreatitis model in lipoprotein lipase-deficient mice. *Acta Physiol (Oxf)*. 2009;195(1):13-28.
 81. McGill HC Jr, McMahan CA, Zieske AW, et al. Associations of coronary heart disease risk factors with the intermediate lesion of atherosclerosis in youth. The Pathobiological Determinants of Atherosclerosis in Youth (PDAY) Research Group. *Arterioscler Thromb Vasc Biol*. 2000;20:1998-2004.
 82. McGill HC Jr, McMahan CA. Determinants of atherosclerosis in the young. Pathobiological Determinants of Atherosclerosis in Youth (PDAY) Research Group. *Am J Cardiol*. 1998;82(10B):30T-36T.
 83. Groner JA, Joshi M, Bauer JA. Pediatric precursors of adult cardiovascular disease: noninvasive assessment of early vascular changes in children and adolescents. *Pediatrics*. 2006;118(4):1683-1691.
 84. Daniels SR, Greer FR; Committee on Nutrition. Lipid screening and cardiovascular health in childhood. *Pediatrics*. 2008;122(1):198-208.
 85. Luirink IK, Wiegman A, Kusters DM, et al. 20-Year follow-up of statins in children with familial hypercholesterolemia. *N Engl J Med*. 2019;381(16):1547-1556.

86. Rodenburg J, Vissers MN, Wiegman A, et al. Statin treatment in children with familial hypercholesterolemia: the younger, the better. *Circulation*. 2007;116(6):664-668.
87. Kusters DM, Avis HJ, de Groot E, et al. Ten-year follow-up after initiation of statin therapy in children with familial hypercholesterolemia. *Jama*. 2014;312(10):1055-1057.
88. Wald DS, Bestwick JP, Morris JK, Whyte K, Jenkins L, Wald NJ. Child-parent familial hypercholesterolemia screening in primary care. *N Engl J Med*. 2016;375(17):1628-1637.
89. Expert Panel on Integrated Guidelines for Cardiovascular Health and Risk Reduction in Children and Adolescents; National Heart, Lung, and Blood Institute. Expert panel on integrated guidelines for cardiovascular health and risk reduction in children and adolescents: summary report. *Pediatrics*. 2011;128 Suppl 5:S213-256.
90. Bibbins-Domingo K, Grossman DC, Curry SJ, et al.; US Preventive Services Task Force. Screening for lipid disorders in children and adolescents: US Preventive Services Task Force recommendation statement. *Jama*. 2016;316(6):625-633.
91. Klančar G, Grošelj U, Kovač J, et al. Universal screening for familial hypercholesterolemia in children. *J Am Coll Cardiol*. 2015;66(11):1250-1257.
92. Wiegman A, Gidding SS, Watts GF, et al.; European Atherosclerosis Society Consensus Panel. Familial hypercholesterolaemia in children and adolescents: gaining decades of life by optimizing detection and treatment. *Eur Heart J*. 2015;36(36):2425-2437.
93. de Ferranti SD, Steinberger J, Ameduri R, et al. Cardiovascular risk reduction in high-risk pediatric patients: a scientific statement from the American Heart Association. *Circulation*. 2019;139(13):e603-e634.
94. Catapano AL, Graham I, De Backer G, et al. 2016 ESC/EAS guidelines for the management of dyslipidaemias. *Rev Esp Cardiol (Engl Ed)*. 2017;70:115.
95. Berg AO, Atkins D. U.S. Preventive Services Task Force: screening for lipid disorders in adults: recommendations and rationale. *Am J Nurs*. 2002;102:91, 93, 95.
96. Bibbins-Domingo K, Grossman DC, Curry SJ, et al. Statin use for the primary prevention of cardiovascular disease in adults: US Preventive Services Task Force Recommendation Statement. *JAMA* 2016;316:1997-2007.
97. Kane JP, Malloy MJ, Ports TA, Phillips NR, Diehl JC, Havel RJ. Regression of coronary atherosclerosis during treatment of familial hypercholesterolemia with combined drug regimens. *Jama*. 1990;264(23):3007-3012.
98. Neil A, Cooper J, Betteridge J, et al. Reductions in all-cause, cancer, and coronary mortality in statin-treated patients with heterozygous familial hypercholesterolaemia: a prospective registry study. *Eur Heart J*. 2008;29(21):2625-2633.
99. Versmissen J, Oosterveer DM, Yazdanpanah M, et al. Efficacy of statins in familial hypercholesterolaemia: a long term cohort study. *Bmj*. 2008;337:a2423.
100. Friedewald WT, Levy RI, Fredrickson DS. Estimation of the concentration of low-density lipoprotein cholesterol in plasma, without use of the preparative ultracentrifuge. *Clin Chem*. 1972;18(6):499-502.
101. Cromwell WC, Otvos JD. Low-density lipoprotein particle number and risk for cardiovascular disease. *Curr Atheroscler Rep*. 2004;6(5):381-387.
102. Stahel P, Xiao C, Hegele RA, Lewis GF. The atherogenic dyslipidemia complex and novel approaches to cardiovascular disease prevention in diabetes. *Can J Cardiol*. 2018;34(5):595-604.
103. Rosenson R, Lloyd-Jones D; Working group from the Adult Treatment Panel III of the National Cholesterol Educational Program. Critical appraisal of revised cholesterol guidelines for the very high-risk patient. *Expert Rev Cardiovasc Ther*. 2005;3(1):173-178.
104. Brunzell JD, Davidson M, Furberg CD, et al. Lipoprotein management in patients with cardiometabolic risk: consensus conference report from the American Diabetes Association and the American College of Cardiology Foundation. *J Am Coll Cardiol*. 2008;51(15):1512-1524.
105. Cui Y, Blumenthal RS, Flaws JA, et al. Non-high-density lipoprotein cholesterol level as a predictor of cardiovascular disease mortality. *Arch Intern Med*. 2001;161(11):1413-1419.
106. Authors/Task Force Members; ESC Committee for Practice Guidelines (CPG); ESC National Cardiac Societies. 2019 ESC/EAS guidelines for the management of dyslipidaemias: lipid modification to reduce cardiovascular risk. *Atherosclerosis*. 2019;290:140-205.
107. Tsai LY, Tsai SM, Lee SC, Liu SF. Falsely low LDL-cholesterol concentrations and artifactual undetectable HDL-cholesterol measured by direct methods in a patient with monoclonal paraprotein. *Clin Chim Acta*. 2005;358(1-2):192-195.
108. Ettinger WH, Varma VK, Sorci-Thomas M, et al. Cytokines decrease apolipoprotein accumulation in medium from Hep G2 cells. *Arterioscler Thromb*. 1994;14(1):8-13.
109. Genest JJ, Corbett HM, McNamara JR, Schaefer MM, Salem DN, Schaefer EJ. Effect of hospitalization on high-density lipoprotein cholesterol in patients undergoing elective coronary angiography. *Am J Cardiol*. 1988;61(13):998-1000.
110. Miller M. Lipid levels in the post-acute coronary syndrome setting: destabilizing another myth? *J Am Coll Cardiol*. 2008;51(15):1446-1447.
111. Kolovou GD, Watts GF, Mikhailidis DP, et al. Postprandial hypertriglyceridaemia revisited in the era of non-fasting lipid profile testing: a 2019 expert panel statement, main text. *Curr Vasc Pharmacol*. 2019;17(5):498-514.
112. Chung S. Update on low-density lipoprotein cholesterol quantification. *Curr Opin Lipidol*. 2019;30(4):273-283.
113. Nordestgaard BG, Langsted A, Mora S, et al.; European Atherosclerosis Society (EAS) and the European Federation of Clinical Chemistry and Laboratory Medicine (EFLM) joint consensus initiative. Fasting is not routinely required for determination of a lipid profile: clinical and laboratory implications including flagging at desirable concentration cut-points—a joint consensus statement from the European Atherosclerosis Society and European Federation of Clinical Chemistry and Laboratory Medicine. *Eur Heart J*. 2016;37:1944-1958.
114. Soran H, Cooper JA, Durrington PN, et al.; Simon Broome Familial Hyperlipidaemia Register Group. Non-HDL or LDL cholesterol in heterozygous familial hypercholesterolaemia: findings of the Simon Broome Register. *Curr Opin Lipidol*. 2020;31(4):167-175.
115. Sniderman A, Langlois M, Cobbaert C. Update on apolipoprotein B. *Curr Opin Lipidol*. 2021;32(4):226-230.

116. Soran H, Ho JH, Adam S, Durrington PN. Non-HDL cholesterol should not generally replace LDL cholesterol in the management of hyperlipidaemia. *Curr Opin Lipidol*. 2019;30(4):263-272.
117. Brownstein AJ, Martin SS. More accurate LDL-C calculation: externally validated, guideline endorsed. *Clin Chim Acta*. 2020;506:149-153.
118. Koch CD, El-Khoury JM. New Sampson low-density lipoprotein equation: better than Friedewald and Martin-Hopkins. *Clin Chem*. 2020;66(8):1120-1121.
119. Robinson JG. What is the role of advanced lipoprotein analysis in practice? *J Am Coll Cardiol*. 2012;60(25):2607-2615.
120. Sniderman AD, Thanassoulis G, Glavinovic T, et al. Apolipoprotein B particles and cardiovascular disease: a narrative review. *JAMA Cardiol*. 2019;4(12):1287-1295.
121. Smellie WS. Testing pitfalls and summary of guidance in lipid management. *Bmj*. 2006;333(7558):83-86.
122. Cohen DE, Anania FA, Chalasani N, National Lipid Association Statin Safety Task Force Liver Expert Panel. An assessment of statin safety by hepatologists. *Am J Cardiol*. 2006;97:77C-81C.
123. Kashani A, Phillips CO, Foody JM, et al. Risks associated with statin therapy: a systematic overview of randomized clinical trials. *Circulation*. 2006;114(25):2788-2797.
124. Hippisley-Cox J, Coupland C. Unintended effects of statins in men and women in England and Wales: population based cohort study using the QResearch database. *Bmj*. 2010;340:c2197.
125. Charles EC, Olson KL, Sandhoff BG, McClure DL, Merenich JA. Evaluation of cases of severe statin-related transaminitis within a large health maintenance organization. *Am J Med*. 2005;118(6):618-624.
126. Smith CC, Bernstein LI, Davis RB, Rind DM, Shmerling RH. Screening for statin-related toxicity: the yield of transaminase and creatine kinase measurements in a primary care setting. *Arch Intern Med*. 2003;163(6):688-692.
127. Chalasani N, Aljadhey H, Kesterson J, Murray MD, Hall SD. Patients with elevated liver enzymes are not at higher risk for statin hepatotoxicity. *Gastroenterology*. 2004;126(5):1287-1292.
128. Hegele RA, Borén J, Ginsberg HN, et al. Rare dyslipidaemias, from phenotype to genotype to management: a European Atherosclerosis Society task force consensus statement. *Lancet Diabetes Endocrinol*. 2020;8(1):50-67.
129. Berberich AJ, Hegele RA. The role of genetic testing in dyslipidaemia. *Pathology*. 2019;51(2):184-192.
130. Berberich AJ, Hegele RA. The complex molecular genetics of familial hypercholesterolaemia. *Nat Rev Cardiol*. 2019;16(1):9-20.
131. Biesecker LG. Correspondence on: "Homozygous familial hypercholesterolemia in Italy: clinical and molecular features." *Atherosclerosis*. 2021;326:63-64.
132. Defesche JC, Gidding SS, Harada-Shiba M, Hegele RA, Santos RD, Wierzbicki AS. Familial hypercholesterolaemia. *Nat Rev Dis Primers*. 2017;3:17093.
133. Hartz J, Hegele RA, Wilson DP. Low LDL cholesterol-friend or foe? *J Clin Lipidol*. 2019;13(3):367-373.
134. Brown EE, Sturm AC, Cuchel M, et al. Genetic testing in dyslipidemia: a scientific statement from the National Lipid Association. *J Clin Lipidol*. 2020;14(4):398-413.
135. Lerner B, Marshall N, Oishi S, et al. The value of genetic testing: beyond clinical utility. *Genet Med*. 2017;19(7):763-771.
136. Vinger PF, Sachs BA. Ocular manifestations of hyperlipoproteinemia. *Am J Ophthalmol*. 1970;70(4):563-573.
137. Bergman R. The pathogenesis and clinical significance of xanthelasma palpebrarum. *J Am Acad Dermatol*. 1994;30(2 Pt 1):236-242.
138. Fujita M, Shirai K. A comparative study of the therapeutic effect of probucol and pravastatin on xanthelasma. *J Dermatol*. 1996;23(9):598-602.
139. Zak A, Zeman M, Slaby A, Vecka M. Xanthomas: clinical and pathophysiological relations. *Biomed Pap Med Fac Univ Palacky Olomouc Czech Repub*. 2014;158(2):181-188.
140. Lugo-Somolinos A, Sánchez JE. Xanthomas: a marker for hyperlipidemias. *Bol Asoc Med P R*. 2003;95(4):12-16.
141. Ference BA, Ginsberg HN, Graham I, et al. Low-density lipoproteins cause atherosclerotic cardiovascular disease. 1. Evidence from genetic, epidemiologic, and clinical studies. A consensus statement from the European Atherosclerosis Society Consensus Panel. *Eur Heart J*. 2017;38(32):2459-2472.
142. Robinson JG. Lipid management beyond the guidelines. *Prog Cardiovasc Dis*. 2019;62(5):384-389.
143. Cuchel M, Bruckert E, Ginsberg HN, et al.; European Atherosclerosis Society Consensus Panel on Familial Hypercholesterolaemia. Homozygous familial hypercholesterolaemia: new insights and guidance for clinicians to improve detection and clinical management. A position paper from the Consensus Panel on Familial Hypercholesterolaemia of the European Atherosclerosis Society. *Eur Heart J*. 2014;35(32):2146-2157.
144. Khera AV, Chaffin M, Zekavat SM, et al. Whole-genome sequencing to characterize monogenic and polygenic contributions in patients hospitalized with early-onset myocardial infarction. *Circulation*. 2019;139(13):1593-1602.
145. Talmud PJ, Shah S, Whittall R, et al. Use of low-density lipoprotein cholesterol gene score to distinguish patients with polygenic and monogenic familial hypercholesterolaemia: a case-control study. *Lancet*. 2013;381(9874):1293-1301.
146. Lazarte J, Hegele RA. Editorial comment: hazards of interpreting genetic reports. *Curr Opin Lipidol*. 2021;32(2):81-82.
147. Dron JS, Hegele RA. Editorial: Discussing polygenic risk with lipid clinic patients. *Curr Opin Lipidol*. 2021;32(4):273-275.
148. D'Agostino RB, Sr., Vasan RS, Pencina MJ, Wolf PA, Cobain M, Massaro JM, Kannel WB. General cardiovascular risk profile for use in primary care: the Framingham Heart Study. *Circulation*. 2008;117:743-753.
149. Conroy RM, Pyörälä K, Fitzgerald AP, et al.; SCORE project group. Estimation of ten-year risk of fatal cardiovascular disease in Europe: the SCORE project. *Eur Heart J*. 2003;24(11):987-1003.
150. Hippisley-Cox J, Coupland C, Vinogradova Y, Robson J, May M, Brindle P. Derivation and validation of QRISK, a new cardiovascular disease risk score for the United Kingdom: prospective open cohort study. *Bmj*. 2007;335(7611):136.
151. Goff DC Jr, Lloyd-Jones DM, Bennett G, et al.; American College of Cardiology/American Heart Association Task Force on Practice Guidelines. 2013 ACC/AHA guideline on the assessment of cardiovascular risk: a report of the American College of Cardiology/American Heart Association Task

- Force on Practice Guidelines. *Circulation*. 2014;129(25 Suppl 2):S49-S73.
152. Risk of Fatal Coronary Heart Disease in Familial Hypercholesterolaemia. Scientific steering committee on behalf of the Simon Broome register group. *BMJ* 1991;303:893-896.
 153. Fouchier SW, Defesche JC, Umans-Eckenhausen MW, Kastelein JP. The molecular basis of familial hypercholesterolemia in The Netherlands. *Hum Genet*. 2001;109(6):602-615.
 154. Umans-Eckenhausen MA, Defesche JC, Sijbrands EJ, Scheerder RL, Kastelein JJ. Review of first 5 years of screening for familial hypercholesterolaemia in the Netherlands. *Lancet*. 2001;357(9251):165-168.
 155. Robinson JG, Rosenson RS, Farnier M, et al. Safety of very low low-density lipoprotein cholesterol levels with alirocumab: pooled data from randomized trials. *J Am Coll Cardiol*. 2017;69(5):471-482.
 156. Soran H, Ho JH, Durrington PN. Acquired low cholesterol: diagnosis and relevance to safety of low LDL therapeutic targets. *Curr Opin Lipidol*. 2018;29(4):318-326.
 157. Giugliano RP, Pedersen TR, Park JG, et al.; FOURIER Investigators. Clinical efficacy and safety of achieving very low LDL-cholesterol concentrations with the PCSK9 inhibitor evolocumab: a prespecified secondary analysis of the FOURIER trial. *Lancet*. 2017;390(10106):1962-1971.
 158. Khera AV, Chaffin M, Aragam KG, et al. Genome-wide polygenic scores for common diseases identify individuals with risk equivalent to monogenic mutations. *Nat Genet* 2018;50(9):1219-1224.
 159. Yuan G, Al-Shali KZ, Hegele RA. Hypertriglyceridemia: its etiology, effects and treatment. *Cmaj*. 2007;176(8):1113-1120.
 160. Feoli-Fonseca JC, Lévy E, Godard M, Lambert M. Familial lipoprotein lipase deficiency in infancy: clinical, biochemical, and molecular study. *J Pediatr*. 1998;133(3):417-423.
 161. Hall LD, Ferringer T. The best diagnosis is: eruptive xanthoma. *Cutis*. 2012;90:12, 15-16
 162. Gotoda T, Shirai K, Ohta T, et al.; Research Committee for Primary Hyperlipidemia, Research on Measures against Intractable Diseases by the Ministry of Health, Labour and Welfare in Japan. Diagnosis and management of type I and type V hyperlipoproteinemia. *J Atheroscler Thromb*. 2012;19(1):1-12.
 163. Fortson MR, Freedman SN, Webster PD 3rd. Clinical assessment of hyperlipidemic pancreatitis. *Am J Gastroenterol*. 1995;90(12):2134-2139.
 164. Kawashiri MA, Higashikata T, Mizuno M, et al. Long-term course of lipoprotein lipase (LPL) deficiency due to homozygous LPL(Arita) in a patient with recurrent pancreatitis, retained glucose tolerance, and atherosclerosis. *J Clin Endocrinol Metab*. 2005;90(12):6541-6544.
 165. Sandhu S, Al-Sarraf A, Taraboanta C, Frohlich J, Francis GA. Incidence of pancreatitis, secondary causes, and treatment of patients referred to a specialty lipid clinic with severe hypertriglyceridemia: a retrospective cohort study. *Lipids Health Dis*. 2011;10:157.
 166. Khokhar AS, Seidner DL. The pathophysiology of pancreatitis. *Nutr Clin Pract*. 2004;19(1):5-15.
 167. Bansal S, Buring JE, Rifai N, Mora S, Sacks FM, Ridker PM. Fasting compared with nonfasting triglycerides and risk of cardiovascular events in women. *Jama*. 2007;298(3):309-316.
 168. Boullart AC, de Graaf J, Stalenhoef AF. Serum triglycerides and risk of cardiovascular disease. *Biochim Biophys Acta*. 2012;1821(5):867-875.
 169. Crosby J, Peloso GM, Auer PL, et al.; TG and HDL Working Group of the Exome Sequencing Project, National Heart, Lung, and Blood Institute. Loss-of-function mutations in APOC3, triglycerides, and coronary disease. *N Engl J Med*. 2014;371:22-31.
 170. Jørgensen AB, Frikke-Schmidt R, Nordestgaard BG, Tybjaerg-Hansen A. Loss-of-function mutations in APOC3 and risk of ischemic vascular disease. *N Engl J Med*. 2014;371(1):32-41.
 171. Marston NA, Giugliano RP, Im K, et al. Association between triglyceride lowering and reduction of cardiovascular risk across multiple lipid-lowering therapeutic classes: a systematic review and meta-regression analysis of randomized controlled trials. *Circulation*. 2019;140(16):1308-1317.
 172. Huet F, Roubille C, Roubille F. Is hypertriglyceridemia atherogenic? *Curr Opin Lipidol*. 2019;30(4):291-299.
 173. Bhatt DL, Steg PG, Miller M, et al.; REDUCE-IT Investigators. Cardiovascular risk reduction with icosapent ethyl for hypertriglyceridemia. *N Engl J Med*. 2019;380(1):11-22.
 174. Wheeler DC, Bernard DB. Lipid abnormalities in the nephrotic syndrome: causes, consequences, and treatment. *Am J Kidney Dis*. 1994;23(3):331-346.
 175. Brahm A, Hegele RA. Hypertriglyceridemia. *Nutrients*. 2013;5(3):981-1001.
 176. Laws A, Stefanick ML, Reaven GM. Insulin resistance and hypertriglyceridemia in nondiabetic relatives of patients with noninsulin-dependent diabetes mellitus. *J Clin Endocrinol Metab*. 1989;69(2):343-347.
 177. Ghio A, Bertolotto A, Resi V, Volpe L, Di Cianni G. Triglyceride metabolism in pregnancy. *Adv Clin Chem*. 2011;55:133-153.
 178. Pedersen SB, Varbo A, Langsted A, Nordestgaard BG. Chylomicronemia risk factors ranked by importance for the individual and community in 108 711 women and men. *J Intern Med*. 2018;283(4):392-404.
 179. Baass A, Paquette M, Bernard S, Hegele RA. Familial chylomicronemia syndrome: an under-recognized cause of severe hypertriglyceridaemia. *J Intern Med*. 2020;287(4):340-348.
 180. Rahalkar AR, Hegele RA. Monogenic pediatric dyslipidemias: classification, genetics and clinical spectrum. *Mol Genet Metab*. 2008;93(3):282-294.
 181. Dron JS, Hegele RA. Genetics of hypertriglyceridemia. *Front Endocrinol (Lausanne)*. 2020;11:455.
 182. Chait A, Brunzell JD. Chylomicronemia syndrome. *Adv Intern Med*. 1992;37:249-273.
 183. Esan O, Wierzbicki AS. Volanesorsen in the treatment of familial chylomicronemia syndrome or hypertriglyceridaemia: design, development and place in therapy. *Drug Des Devel Ther*. 2020;14:2623-2636.
 184. Witztum JL, Gaudet D, Freedman SD, et al. Volanesorsen and triglyceride levels in familial chylomicronemia syndrome. *N Engl J Med*. 2019;381(6):531-542.
 185. Warden BA, Duell PB. Volanesorsen for treatment of patients with familial chylomicronemia syndrome. *Drugs Today (Barc)*. 2018;54(12):721-735.
 186. Khetarpal SA, Wang M, Khera AV. Volanesorsen, familial chylomicronemia syndrome, and thrombocytopenia. *N Engl J Med*. 2019;381(26):2582-2584.

187. Gaudet D, Karwatowska-Prokopczuk E, Baum SJ, et al.; Vupanorsen Study Investigators. Vupanorsen, an N-acetyl galactosamine-conjugated antisense drug to ANGPTL3 mRNA, lowers triglycerides and atherogenic lipoproteins in patients with diabetes, hepatic steatosis, and hypertriglyceridaemia. *Eur Heart J*. 2020;41(40):3936-3945.
188. Walden CC, Hegele RA. Apolipoprotein E in hyperlipidemia. *Ann Intern Med*. 1994;120(12):1026-1036.
189. Mahley RW, Huang Y, Rall SC, Jr. Pathogenesis of type III hyperlipoproteinemia (dysbetalipoproteinemia). Questions, quandaries, and paradoxes. *J Lipid Res*. 1999;40:1933-1949.
190. Koopal C, Marais AD, Visseren FL. Familial dysbetalipoproteinemia: an underdiagnosed lipid disorder. *Curr Opin Endocrinol Diabetes Obes*. 2017;24(2):133-139.
191. Le R, Abbas M, McIntyre AD, Hegele RA. Severe combined dyslipidemia with a complex genetic basis. *J Investig Med High Impact Case Rep*. 2019;7:2324709619877050.
192. Zhu Y, Pan X, Zeng H, et al. A study on the etiology, severity, and mortality of 3260 patients with acute pancreatitis according to the revised Atlanta classification in Jiangxi, China over an 8-year period. *Pancreas*. 2017;46(4):504-509.
193. Nawaz H, Koutroumpakis E, Easler J, et al. Elevated serum triglycerides are independently associated with persistent organ failure in acute pancreatitis. *Am J Gastroenterol*. 2015;110(10):1497-1503.
194. Wan J, He W, Zhu Y, et al. Stratified analysis and clinical significance of elevated serum triglyceride levels in early acute pancreatitis: a retrospective study. *Lipids Health Dis*. 2017;16(1):124.
195. Alagözülü H, Cindoruk M, Karakan T, Unal S. Heparin and insulin in the treatment of hypertriglyceridemia-induced severe acute pancreatitis. *Dig Dis Sci*. 2006;51(5):931-933.
196. Jabbar MA, Zuhri-Yafi MI, Larrea J. Insulin therapy for a non-diabetic patient with severe hypertriglyceridemia. *J Am Coll Nutr*. 1998;17(5):458-461.
197. Betteridge DJ, Bakowski M, Taylor KG, Reckless JP, de Silva SR, Galton DJ. Treatment of severe diabetic hypertriglyceridaemia by plasma exchange. *Lancet*. 1978;1(8078):1368.
198. Chen JH, Yeh JH, Lai HW, Liao CS. Therapeutic plasma exchange in patients with hyperlipidemic pancreatitis. *World J Gastroenterol*. 2004;10(15):2272-2274.
199. Berberich AJ, Ziada A, Zou GY, Hegele RA. Conservative management in hypertriglyceridemia-associated pancreatitis. *J Intern Med*. 2019;286(6):644-650.
200. Thuzar M, Shenoy VV, Malabu UH, Schrale R, Sangla KS. Extreme hypertriglyceridemia managed with insulin. *J Clin Lipidol*. 2014;8(6):630-634.
201. Newman CB, Blaha MJ, Boord JB, et al. Lipid management in patients with endocrine disorders: an Endocrine Society Clinical Practice Guideline. *J Clin Endocrinol Metab*. 2020;105.
202. Pedersen SB, Langsted A, Nordestgaard BG. Nonfasting mild-to-moderate hypertriglyceridemia and risk of acute pancreatitis. *JAMA Intern Med*. 2016;176(12):1834-1842.
203. US Food and Drug Administration. *Statins: drug safety communication—FDA requests removal of strongest warning against using cholesterol-lowering statins during pregnancy*. 2021. <https://www.fda.gov/safety/medical-product-safety-information/statins-drug-safety-communication-fda-requests-removal-strongest-warning-against-using-cholesterol>
204. Goldberg AS, Hegele RA. Severe hypertriglyceridemia in pregnancy. *J Clin Endocrinol Metab*. 2012;97(8):2589-2596.
205. Chyzyk V, Kozmic S, Brown AS, et al. Extreme hypertriglyceridemia: genetic diversity, pancreatitis, pregnancy, and prevalence. *J Clin Lipidol*. 2019;13(1):89-99.
206. Ko DT, Alter DA, Guo H, et al. High-density lipoprotein cholesterol and cause-specific mortality in individuals without previous cardiovascular conditions: the CANHEART study. *J Am Coll Cardiol*. 2016;68:2073-2083.
207. Hamer M, O'Donovan G, Stamatakis E. High-density lipoprotein cholesterol and mortality: too much of a good thing? *Arterioscler Thromb Vasc Biol*. 2018;38(3):669-672.
208. Oh IH, Hur JK, Ryou JH, et al. Very high high-density lipoprotein cholesterol is associated with increased all-cause mortality in South Koreans. *Atherosclerosis*. 2019;283:43-51.
209. Martinez LO, Ingueneau C, Genoux A. Is it time to reconcile HDL with cardiovascular diseases and beyond? An update on a paradigm shift. *Curr Opin Lipidol*. 2020;31(5):302-304.
210. Asztalos BF, Niisuke K, Horvath KV. High-density lipoprotein: our elusive friend. *Curr Opin Lipidol*. 2019;30(4):314-319.
211. Rhoads D, Tardif JC. From HDL-cholesterol to HDL-function: cholesterol efflux capacity determinants. *Curr Opin Lipidol*. 2019;30(2):101-107.
212. Wilkins JT, Seckler HS. HDL modification: recent developments and their relevance to atherosclerotic cardiovascular disease. *Curr Opin Lipidol*. 2019;30(1):24-29.
213. Schaefer EJ, Geller AS, Endress G. The biochemical and genetic diagnosis of lipid disorders. *Curr Opin Lipidol*. 2019;30(2):56-62.
214. Ruiz-Ramie JJ, Barber JL, Sarzynski MA. Effects of exercise on HDL functionality. *Curr Opin Lipidol*. 2019;30(1):16-23.
215. Sourlas A, Kosmas CE. Inheritance of high and low HDL: mechanisms and management. *Curr Opin Lipidol*. 2019;30(4):307-313.
216. Dron JS, Wang J, Low-Kam C, et al. Polygenic determinants in extremes of high-density lipoprotein cholesterol. *J Lipid Res*. 2017;58(11):2162-2170.
217. Hooper AJ, Hegele RA, Burnett JR. Tangier disease: update for 2020. *Curr Opin Lipidol*. 2020;31(2):80-84.
218. Zanoni P, von Eckardstein A. Inborn errors of apolipoprotein A-I metabolism: implications for disease, research and development. *Curr Opin Lipidol*. 2020;31(2):62-70.
219. Pavanello C, Calabresi L. Genetic, biochemical, and clinical features of LCAT deficiency: update for 2020. *Curr Opin Lipidol*. 2020;31(4):232-237.
220. May SC, Dron JS, Hegele RA, Sahoo D. Human variant of scavenger receptor BI (R174C) exhibits impaired cholesterol transport functions. *J Lipid Res*. 2021;62:100045.
221. Yamashita S, Matsuzawa Y. Re-evaluation of cholesteryl ester transfer protein function in atherosclerosis based upon genetics and pharmacological manipulation. *Curr Opin Lipidol*. 2016;27(5):459-472.
222. Ruel IL, Couture P, Gagne C, et al. Characterization of a novel mutation causing hepatic lipase deficiency among French Canadians. *J Lipid Res*. 2003;44(8):1508-1514.
223. Luijten J, van Greevenbroek MMJ, Schaper NC, et al. Incidence of cardiovascular disease in familial combined hyperlipidemia: a 15-year follow-up study. *Atherosclerosis*. 2019;280:1-6.
224. Genest J. Lipoprotein disorders and cardiovascular risk. *J Inherit Metab Dis*. 2003;26(2-3):267-287.
225. Holewijn S, Sniderman AD, den Heijer M, Swinkels DW, Stalenhoef AF, de Graaf J. Application and

- validation of a diagnostic algorithm for the atherogenic apoB dyslipoproteinemias: ApoB dyslipoproteinemias in a Dutch population-based study. *Eur J Clin Invest*. 2011;41(4):423-433.
226. Sniderman AD, Robinson JG. ApoB in clinical care: Pro and Con. *Atherosclerosis*. 2019;282:169-175.
227. Xiao C, Dash S, Morgantini C, Hegele RA, Lewis GF. Pharmacological targeting of the atherogenic dyslipidemia complex: the next frontier in CVD prevention beyond lowering LDL cholesterol. *Diabetes*. 2016;65(7):1767-1778.
228. Brahm AJ, Hegele RA. Combined hyperlipidemia: familial but not (usually) monogenic. *Curr Opin Lipidol*. 2016;27(2):131-140.
229. Steyrer E, Durovic S, Frank S, et al. The role of lecithin: cholesterol acyltransferase for lipoprotein (a) assembly. Structural integrity of low density lipoproteins is a prerequisite for Lp(a) formation in human plasma. *J Clin Invest*. 1994;94(6):2330-2340.
230. Albers JJ, Kennedy H, Marcovina SM. Evidence that Lp[a] contains one molecule of apo[a] and one molecule of apoB: evaluation of amino acid analysis data. *J Lipid Res*. 1996;37(1):192-196.
231. Boerwinkle E, Leffert CC, Lin J, Lackner C, Chiesa G, Hobbs HH. Apolipoprotein(a) gene accounts for greater than 90% of the variation in plasma lipoprotein(a) concentrations. *J Clin Invest*. 1992;90(1):52-60.
232. Palabrica TM, Liu AC, Aronovitz MJ, Furie B, Lawn RM, Furie BC. Antifibrinolytic activity of apolipoprotein(a) in vivo: human apolipoprotein(a) transgenic mice are resistant to tissue plasminogen activator-mediated thrombolysis. *Nat Med*. 1995;1(3):256-259.
233. Zioncheck TF, Powell LM, Rice GC, Eaton DL, Lawn RM. Interaction of recombinant apolipoprotein(a) and lipoprotein(a) with macrophages. *J Clin Invest*. 1991;87(3):767-771.
234. Dangas G, Mehran R, Harpel PC, et al. Lipoprotein(a) and inflammation in human coronary atheroma: association with the severity of clinical presentation. *J Am Coll Cardiol*. 1998;32:2035-2042.
235. Gudbjartsson DF, Thorgerirsson G, Sulem P, et al. Lipoprotein(a) concentration and risks of cardiovascular disease and diabetes. *J Am Coll Cardiol*. 2019;74(24):2982-2994.
236. Wilson DP, Jacobson TA, Jones PH, et al. Use of Lipoprotein(a) in clinical practice: a biomarker whose time has come. A scientific statement from the National Lipid Association. *J Clin Lipidol*. 2019;13(3):374-392.
237. Erqou S, Kaptoge S, Perry PL, et al.; Emerging Risk Factors Collaboration. Lipoprotein(a) concentration and the risk of coronary heart disease, stroke, and nonvascular mortality. *JAMA*. 2009;302(4):412-423.
238. Grundy SM, Stone NJ, Bailey AL, et al. 2018 AHA/ACC/AACVPR/AAPA/ABC/ACPM/ADA/AGS/APhA/ASPC/NLA/PCNA Guideline on the management of blood cholesterol: executive summary: a report of the American College of Cardiology/American Heart Association Task Force on Clinical Practice Guidelines. *Circulation*. 2019;139(25):e1046-e1081.
239. Tsimikas S, Karwatowska-Prokopczyk E, Gouni-Berthold I, et al.; AKCEA-APO(a)-LRx Study Investigators. Lipoprotein(a) reduction in persons with cardiovascular disease. *N Engl J Med*. 2020;382(3):244-255.
240. Tsimikas S, Gordts PLSM, Nora C, Yeang C, Witztum JL. Statin therapy increases lipoprotein(a) levels. *Eur Heart J*. 2020;41(24):2275-2284.
241. Navarese EP, Kolodziejczak M, Schulze V, et al. Effects of proprotein convertase subtilisin/kexin type 9 antibodies in adults with hypercholesterolemia: a systematic review and meta-analysis. *Ann Intern Med*. 2015;163(1):40-51.
242. Vergès B. Dyslipidemia in type 1 diabetes: a masked danger. *Trends Endocrinol Metab*. 2020;31(6):422-434.
243. Gotto AM, Jr. Hypertriglyceridemia: risks and perspectives. *Am J Cardiol*. 1992;70:19H-25H.
244. Brown L, Rosner B, Willett WW, Sacks FM. Cholesterol-lowering effects of dietary fiber: a meta-analysis. *Am J Clin Nutr*. 1999;69(1):30-42.
245. Miettinen TA, Puska P, Gylling H, Vanhanen H, Vartiainen E. Reduction of serum cholesterol with sitostanol-ester margarine in a mildly hypercholesterolemic population. *N Engl J Med*. 1995;333(20):1308-1312.
246. Hirota T, Fujita Y, Ieiri I. An updated review of pharmacokinetic drug interactions and pharmacogenetics of statins. *Expert Opin Drug Metab Toxicol*. 2020;16(9):809-822.
247. Watts GF, Barrett PH, Ji J, et al. Differential regulation of lipoprotein kinetics by atorvastatin and fenofibrate in subjects with the metabolic syndrome. *Diabetes*. 2003;52(3):803-811.
248. Borén J, Chapman MJ, Krauss RM, et al. Low-density lipoproteins cause atherosclerotic cardiovascular disease: pathophysiological, genetic, and therapeutic insights: a consensus statement from the European Atherosclerosis Society Consensus Panel. *Eur Heart J*. 2020;41(24):2313-2330.
249. Fulcher J, O'Connell R, Voysey M, et al.; Cholesterol Treatment Trialists' (CTT) Collaboration. Efficacy and safety of LDL-lowering therapy among men and women: meta-analysis of individual data from 174 000 participants in 27 randomised trials. *Lancet*. 2015;385(9976):1397-1405.
250. Packard CJ. Strategies to alter the trajectory of atherosclerotic cardiovascular disease. *Curr Opin Lipidol*. 2019;30(6):438-445.
251. Mach F, Ray KK, Wiklund O, et al.; European Atherosclerosis Society Consensus Panel. Adverse effects of statin therapy: perception vs. the evidence—focus on glucose homeostasis, cognitive, renal and hepatic function, haemorrhagic stroke and cataract. *Eur Heart J*. 2018;39(27):2526-2539.
252. Bruckert E, Hayem G, Dejager S, Yau C, Bégaud B. Mild to moderate muscular symptoms with high-dosage statin therapy in hyperlipidemic patients—the PRIMO study. *Cardiovasc Drugs Ther*. 2005;19(6):403-414.
253. Zhang H, Plutzky J, Skentzos S, et al. Discontinuation of statins in routine care settings: a cohort study. *Ann Intern Med*. 2013;158(7):526-534.
254. Cohen JD, Brinton EA, Ito MK, Jacobson TA. Understanding Statin Use in America and Gaps in Patient Education (USAGE): an internet-based survey of 10 138 current and former statin users. *J Clin Lipidol*. 2012;6(3):208-215.
255. Stroes ES, Thompson PD, Corsini A, et al.; European Atherosclerosis Society Consensus Panel. Statin-associated muscle symptoms: impact on statin therapy-European Atherosclerosis Society Consensus Panel Statement on Assessment, Aetiology and Management. *Eur Heart J*. 2015;36(17):1012-1022.

256. Toth PP, Patti AM, Giglio RV, et al. Management of statin intolerance in 2018: still more questions than answers. *Am J Cardiovasc Drugs*. 2018;18(3):157-173.
257. Jacobson TA, Ito MK, Maki KC, et al. National lipid association recommendations for patient-centered management of dyslipidemia: part 1—executive summary. *J Clin Lipidol*. 2014;8(5):473-488.
258. Joy TR, Monjed A, Zou GY, Hegele RA, McDonald CG, Mahon JL. N-of-1 (single-patient) trials for statin-related myalgia. *Ann Intern Med*. 2014;160(5):301-310.
259. Wood FA, Howard JP, Finegold JA, et al. N-of-1 trial of a statin, placebo, or no treatment to assess side effects. *N Engl J Med*. 2020;383(22):2182-2184.
260. Harper CR, Jacobson TA. The broad spectrum of statin myopathy: from myalgia to rhabdomyolysis. *Curr Opin Lipidol*. 2007;18(4):401-408.
261. Feingold KR. Maximizing the benefits of cholesterol-lowering drugs. *Curr Opin Lipidol*. 2019;30(5):388-394.
262. Cannon CP, Blazing MA, Giugliano RP, et al.; IMPROVE-IT Investigators. Ezetimibe added to statin therapy after acute coronary syndromes. *N Engl J Med*. 2015;372(25):2387-2397.
263. Ouchi Y, Sasaki J, Arai H, et al. Ezetimibe lipid-lowering trial on prevention of atherosclerotic cardiovascular disease in 75 or older (EWTOPIA 75): a randomized, controlled trial. *Circulation*. 2019;140(12):992-1003.
264. Baigent C, Landray MJ, Reith C, et al.; SHARP Investigators. The effects of lowering LDL cholesterol with simvastatin plus ezetimibe in patients with chronic kidney disease (Study of Heart and Renal Protection): a randomised placebo-controlled trial. *Lancet*. 2011;377(9784):2181-2192.
265. Rakipovski G, Hovingh GK, Nyberg M. Proprotein convertase subtilisin/kexin type 9 inhibition as the next statin? *Curr Opin Lipidol*. 2020;31(6):340-346.
266. Spolitu S, Dai W, Zadroga JA, Ozcan L. Proprotein convertase subtilisin/kexin type 9 and lipid metabolism. *Curr Opin Lipidol*. 2019;30(3):186-191.
267. Kent ST, Rosenson RS, Avery CL, et al. PCSK9 loss-of-function variants, low-density lipoprotein cholesterol, and risk of coronary heart disease and stroke: Data from 9 studies of blacks and whites. *Circ Cardiovasc Genet*. 2017;10(4):e001632.
268. Sabatine MS. PCSK9 inhibitors: clinical evidence and implementation. *Nat Rev Cardiol*. 2019;16(3):155-165.
269. Lee S, Cannon CP. Combination lipid-lowering therapies for the prevention of recurrent cardiovascular events. *Curr Cardiol Rep*. 2018;20(7):55.
270. Nicholls SJ, Puri R, Anderson T, et al. Effect of evolocumab on progression of coronary disease in statin-treated patients: the GLAGOV randomized clinical trial. *JAMA*. 2016;316(22):2373-2384.
271. Civeira F, Pedro-Botet J. Cost-effectiveness evaluation of the use of PCSK9 inhibitors. *Endocrinol Diabetes Nutr*. 2021;68:369-371.
272. Tiwari V, Khokhar M. Mechanism of action of anti-hypercholesterolemia drugs and their resistance. *Eur J Pharmacol*. 2014;741:156-170.
273. Mazidi M, Rezaie P, Karimi E, Kengne AP. The effects of bile acid sequestrants on lipid profile and blood glucose concentrations: a systematic review and meta-analysis of randomized controlled trials. *Int J Cardiol*. 2017;227:850-857.
274. Creider JC, Hegele RA, Joy TR. Niacin: another look at an underutilized lipid-lowering medication. *Nat Rev Endocrinol*. 2012;8(9):517-528.
275. Landray MJ, Haynes R, Hopewell JC, et al.; HPS2-THRIVE Collaborative Group. Effects of extended-release niacin with laropirant in high-risk patients. *N Engl J Med*. 2014;371(3):203-212.
276. Cuchel M, Meagher EA, du Toit Theron H, et al.; Phase 3 HoFH Lomitapide Study investigators. Efficacy and safety of a microsomal triglyceride transfer protein inhibitor in patients with homozygous familial hypercholesterolemia: a single-arm, open-label, phase 3 study. *Lancet*. 2013;381(9860):40-46.
277. Berberich AJ, Hegele RA. Lomitapide for the treatment of hypercholesterolemia. *Expert Opin Pharmacother*. 2017;18(12):1261-1268.
278. Brahm AJ, Hegele RA. Lomitapide for the treatment of hypertriglyceridemia. *Expert Opin Investig Drugs*. 2016;25(12):1457-1463.
279. Cuchel M, Rader DJ. Microsomal transfer protein inhibition in humans. *Curr Opin Lipidol*. 2013;24(3):246-250.
280. Blom DJ, Aversa MR, Meagher EA, et al. Long-term efficacy and safety of the microsomal triglyceride transfer protein inhibitor lomitapide in patients with homozygous familial hypercholesterolemia. *Circulation*. 2017;136(3):332-335.
281. Reijman MD, Kusters DM, Wiegman A. Advances in familial hypercholesterolemia in children. *Lancet Child Adolesc Health*. 2021;5(9):652-661.
282. Kayikcioglu M. LDL Apheresis and Lp (a) apheresis: a clinician's perspective. *Curr Atheroscler Rep*. 2021;23(4):15.
283. Bélanger AM, Akioyamen L, Alothman L, Genest J. Evidence for improved survival with treatment of homozygous familial hypercholesterolemia. *Curr Opin Lipidol*. 2020;31(4):176-181.
284. Ganda OP. When to lower triglycerides? *Curr Opin Lipidol*. 2020;31(4):238-245.
285. Mancini GBJ, Hegele RA, Leiter LA; Diabetes Canada Clinical Practice Guidelines Expert Committee. Dyslipidemia. *Can J Diabetes*. 2018;42 Suppl 1:S178-S185.
286. Fruchart JC, Santos RD. SPPARM alpha: the Lazarus effect. *Curr Opin Lipidol*. 2019;30(6):419-427.
287. Pradhan AD, Paynter NP, Everett BM, et al. Rationale and design of the pemafibrate to reduce cardiovascular outcomes by reducing triglycerides in patients with diabetes (PROMINENT) study. *Am Heart J*. 2018;206:80-93.
288. Liu QK. Triglyceride-lowering and anti-inflammatory mechanisms of omega-3 polyunsaturated fatty acids for atherosclerotic cardiovascular risk reduction. *J Clin Lipidol*. 2021;S1933-2874(21)00108-2.
289. Nicholls SJ, Nelson AJ. The fish-oil paradox. *Curr Opin Lipidol*. 2020;31(6):356-361.
290. Nicholls SJ, Lincoff AM, Garcia M, et al. Effect of high-dose omega-3 fatty acids vs corn oil on major adverse cardiovascular events in patients at high cardiovascular risk: the STRENGTH randomized clinical trial. *JAMA*. 2020;324(22):2268-2280.
291. Hegele RA, Tsimikas S. Lipid-lowering agents. *Circ Res*. 2019;124(3):386-404.
292. Burke AC, Telford DE, Huff MW. Bempedoic acid: effects on lipoprotein metabolism and atherosclerosis. *Curr Opin Lipidol*. 2019;30(1):1-9.

293. Ballantyne CM, Bays H, Catapano AL, Goldberg A, Ray KK, Saseen JJ. Role of bempedoic acid in clinical practice. *Cardiovasc Drugs Ther.* 2021;35(4):853-864.
294. Marrs JC, Anderson SL. Bempedoic acid for the treatment of dyslipidemia. *Drugs Context* 2020;9.
295. Nicholls S, Lincoff AM, Bays HE, et al. Rationale and design of the CLEAR-outcomes trial: Evaluating the effect of bempedoic acid on cardiovascular events in patients with statin intolerance. *Am Heart J.* 2021;235:104-112.
296. Brandts J, Ray KK. Small interfering RNA to proprotein convertase subtilisin/kexin type 9: transforming LDL-cholesterol-lowering strategies. *Curr Opin Lipidol.* 2020;31(4):182-186.
297. Khan SA, Naz A, Qamar Masood M, Shah R. Meta-analysis of inclisiran for the treatment of hypercholesterolemia. *Am J Cardiol.* 2020;134:69-73.
298. Byrne P, Cullinan J, Mintzes B, Smith SM. UK deal over inclisiran. *BMJ.* 2020;368:m579.
299. Stoekenbroek RM, Kallend D, Wijngaard PL, Kastelein JJ. Inclisiran for the treatment of cardiovascular disease: the ORION clinical development program. *Future Cardiol.* 2018;14(6):433-442.
300. Gaudet D, Durst R, Lepor N, et al. Usefulness of gemcabene in homozygous familial hypercholesterolemia (from COBALT-1). *Am J Cardiol.* 2019;124(12):1876-1880.
301. Basu D, Goldberg IJ. Regulation of lipoprotein lipase-mediated lipolysis of triglycerides. *Curr Opin Lipidol.* 2020;31(3):154-160.
302. Huff MW, Hegele RA. Apolipoprotein C-III: going back to the future for a lipid drug target. *Circ Res.* 2013;112(11):1405-1408.
303. Gill PK, Dron JS, Hegele RA. Genetics of hypertriglyceridemia and atherosclerosis. *Curr Opin Cardiol.* 2021;36(3):264-271.
304. D'Erasmus L, Gallo A, Di Costanzo A, Bruckert E, Arca M. Evaluation of efficacy and safety of antisense inhibition of apolipoprotein C-III with volanesorsen in patients with severe hypertriglyceridemia. *Expert Opin Pharmacother.* 2020;21(14):1675-1684.
305. Gouni-Berthold I, Alexander VJ, Yang Q, et al.; COMPASS study group. Efficacy and safety of volanesorsen in patients with multifactorial chylomicronaemia (COMPASS): a multicentre, double-blind, randomised, placebo-controlled, phase 3 trial. *Lancet Diabetes Endocrinol.* 2021;9(5):264-275.
306. Alexander VJ, Xia S, Hurh E, et al. N-acetyl galactosamine-conjugated antisense drug to APOC3 mRNA, triglycerides and atherogenic lipoprotein levels. *Eur Heart J.* 2019;40(33):2785-2796.
307. Akoumianakis I, Zvintzou E, Kypreos K, Filippatos TD. ANGPTL3 and apolipoprotein C-III as novel lipid-lowering targets. *Curr Atheroscler Rep.* 2021;23(5):20.
308. Kersten S. New insights into angiopoietin-like proteins in lipid metabolism and cardiovascular disease risk. *Curr Opin Lipidol.* 2019;30(3):205-211.
309. Arca M, D'Erasmus L, Minicocci I. Familial combined hypolipidemia: angiopoietin-like protein-3 deficiency. *Curr Opin Lipidol.* 2020;31(2):41-48.
310. Reeskamp LF, Tromp TR, Stroes ESG. The next generation of triglyceride-lowering drugs: will reducing apolipoprotein C-III or angiopoietin like protein 3 reduce cardiovascular disease? *Curr Opin Lipidol.* 2020;31(3):140-146.
311. Reeskamp LF, Millar JS, Wu L, et al. ANGPTL3 inhibition with evinacumab results in faster clearance of IDL and LDL apoB in patients with homozygous familial hypercholesterolemia-brief report. *Arterioscler Thromb Vasc Biol.* 2021;41(5):1753-1759.
312. Raal FJ, Rosenson RS, Reeskamp LF, et al.; ELIPSE HoFH Investigators. Evinacumab for homozygous familial hypercholesterolemia. *N Engl J Med.* 2020;383(8):711-720.
313. Rosenson RS, Burgess LJ, Ebenbichler CF, et al. Evinacumab in patients with refractory hypercholesterolemia. *N Engl J Med.* 2020;383(24):2307-2319.
314. Kuehn BM. Evinacumab approval adds a new option for homozygous familial hypercholesterolemia with a hefty price tag. *Circulation.* 2021;143(25):2494-2496.
315. Ahmad Z, Porody R, Rader DJ, et al. Inhibition of angiopoietin-like protein 3 with evinacumab in subjects with high and severe hypertriglyceridemia. *J Am Coll Cardiol.* 2021;78(2):193-195.
316. Mohamed F, Botha TC, Raal FJ. Inhibition of angiopoietin-like 3 for the management of severe hypercholesterolemia. *Curr Opin Lipidol.* 2021;32(4):213-218.
317. Wolska A, Reimund M, Remaley AT. Apolipoprotein C-II: the re-emergence of a forgotten factor. *Curr Opin Lipidol.* 2020;31(3):147-153.
318. Dewey FE, Gusarova V, O'Dushlaine C, et al. Inactivating variants in ANGPTL4 and risk of coronary artery disease. *N Engl J Med.* 2016;374(12):1123-1133.
319. Langsted A, Nordestgaard BG. Lipoprotein(a): is it more, less or equal to LDL as a causal factor for cardiovascular disease and mortality? *Curr Opin Lipidol.* 2020;31(3):125-131.
320. Boffa MB, Koschinsky ML. Proprotein convertase subtilisin/kexin type 9 inhibitors and lipoprotein(a)-mediated risk of atherosclerotic cardiovascular disease: more than meets the eye? *Curr Opin Lipidol.* 2019;30(6):428-437.
321. Chan DC, Watts GF. Metabolism of lipoprotein(a): new findings, implications and outstanding issues. *Curr Opin Lipidol.* 2020;31(3):163-165.
322. Burkhardt R. Hyperlipidemia and cardiovascular disease: new insights on lipoprotein(a). *Curr Opin Lipidol.* 2019;30(3):260-261.
323. Viney NJ, van Capelleveen JC, Geary RS, et al. Antisense oligonucleotides targeting apolipoprotein(a) in people with raised lipoprotein(a): two randomised, double-blind, placebo-controlled, dose-ranging trials. *Lancet.* 2016;388(10057):2239-2253.
324. Nicholls SJ, Bubbs KJ. The riskier lipid: what is on the HORIZON for lipoprotein (a) and should there Be Lp(a) screening for all? *Curr Cardiol Rep.* 2021;23(8):97.
325. Doggrel SA. What have we learnt from the clinical outcomes trials with the cetrapiBs? *Curr Opin Lipidol.* 2018;29(4):327-332.
326. Zheng KH, Kaiser Y, van Olden CC, et al. No benefit of HDL mimetic CER-001 on carotid atherosclerosis in patients with genetically determined very low HDL levels. *Atherosclerosis.* 2020;311:13-19.
327. Bertrand MJ, Dubé MP, Tardif JC. Pharmacogenomic approaches to lipid-regulating trials. *Curr Opin Lipidol.* 2016;27(6):557-562.
328. Tardif JC, Dubé MP, Pfeffer MA, et al.; dal-GenE Investigators. Study design of Dal-GenE, a pharmacogenetic trial targeting reduction of cardiovascular events with dalcetrapib. *Am Heart J.* 2020;222:157-165.
329. Freeman LA, Karathanasis SK, Remaley AT. Novel lecithin: cholesterol acyltransferase-based therapeutic approaches. *Curr Opin Lipidol.* 2020;31(2):71-79.